

W|ECO® VERTICAL ARROW BOARD TRAILERS

MODEL WTSV
PRODUCT SPECIFICATIONS | APRIL 2024

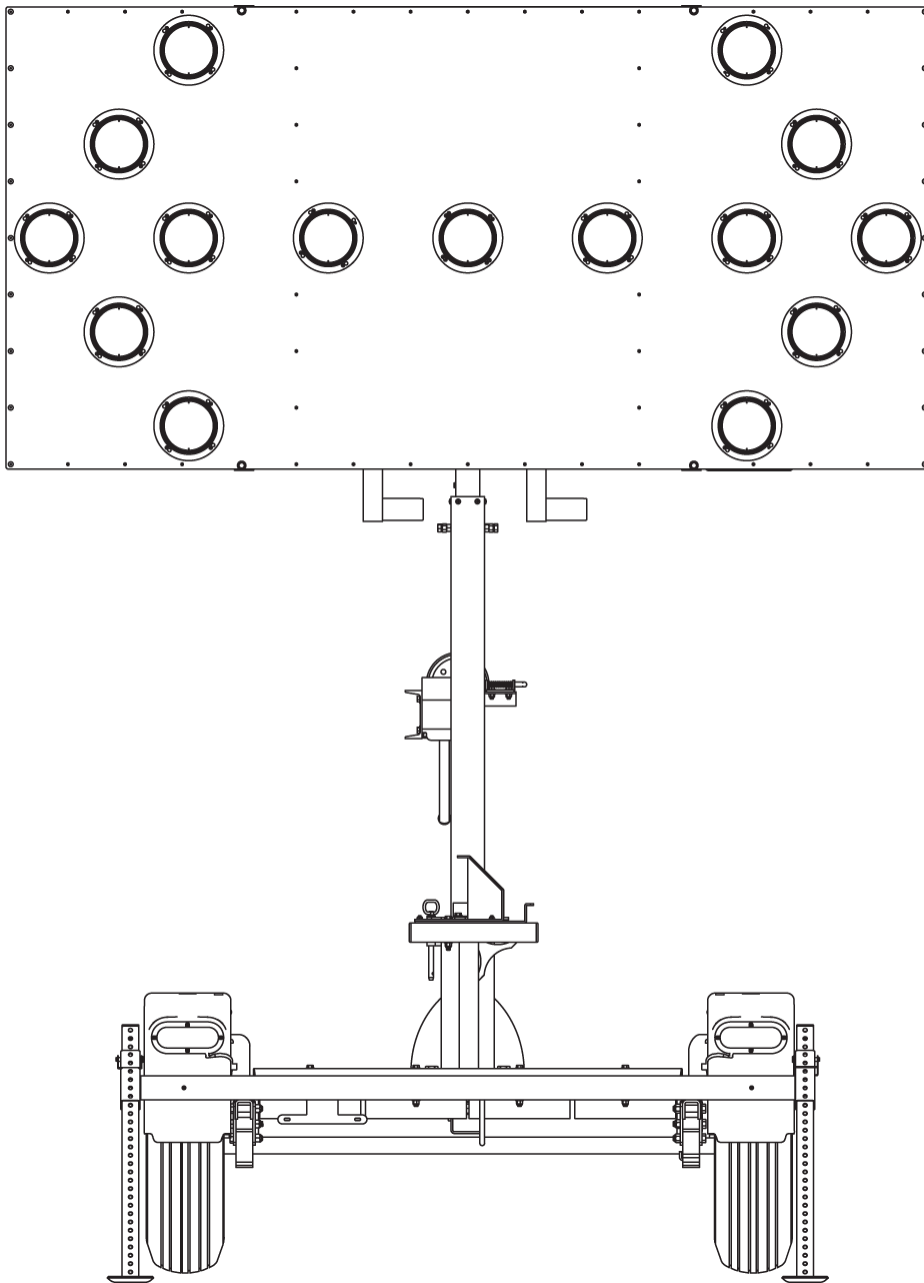

1. DESCRIPTION

- 1.1. Description
- Arrow boards direct traffic by flashing a brightly lit arrow pattern on a large, highly visible display panel. Wanco® Arrow Board Trailers are portable and self-powered, requiring no permanent installation or wiring. Arrows and other patterns are selected by the user.
- Wanco Vertical Arrow Boards feature a display panel that remains vertical at all times. The display is raised and lowered on a vertical tower that rotates for orienting toward traffic without moving the trailer. When the tower is lowered for transport or storage, the display panel rests in a cradle that holds it secure in place.
- Wanco Arrow Boards feature W|ECO® technology, a highly efficient power system. With Wanco's exclusive LED lamps and small, eco-friendly batteries, W|ECO arrow boards are extremely energy-efficient without sacrificing performance. Power is provided by batteries, which are charged by an automated solar charging system. With sufficient sunlight, W|ECO arrow boards can run indefinitely without intervention.
- Wanco Arrow Boards are also connected to the cloud. Connected Arrow Boards send digital alerts to warn drivers of hazards in advance, helping to increase driver awareness, improve roadway safety and reduce work zone fatalities.
- 1.2. Models
- 1.2.1. WTSV-LSA Arrow-board trailer with vertical tower and 15-light display panel
- 1.2.2. WTSV-LSAC Arrow-board trailer with vertical tower and 25-light display panel

2. FEATURES

- 2.1. Operation
- High-output amber LEDs
 - Selection of arrow and other display patterns
 - Easy to operate and maintain
 - Heavy-duty hand-winch with safety brake allows one person to raise display panel
 - Display panel rotates for positioning without moving trailer
 - Controller, batteries, and all wiring mounted to display panel frame
 - Weather-resistant control box cover has lockable slam-latch
 - Control box outputs have short-circuit protection, helping prevent blown transistors
 - Arrow display has automatic dimming
 - Stabilizer legs raise tires off the ground to provide stability in high wind
 - Meets MUTCD

- 2.2. Power system
 - Energy-efficient operation results in long run times
 - Solar panel charges batteries automatically without intervention
 - Charging system shuts down when batteries are fully charged, preventing damage
 - Unique system allows battery charging with solar panel or commercial power
 - Power system includes reverse polarity protection and low-voltage disconnect circuit
 - Controller has resettable fuses
 - Solar charging system features solid state voltage regulator with charge indicator
- 2.3. Maintenance
 - Maintenance-free batteries
 - Durable powder-coat finish resists the elements
 - Lamps and visors are easily replaced
 - Standard trailer tires
 - Heavy-duty bolt-on fenders can be replaced if damaged
- 2.4. Environmental
 - Consumes 80% less power than traditional solar arrow boards
 - Small batteries have 80% less lead content
 - Sealed batteries will not leak or spill
 - Decreased charging time saves energy and downtime
 - Manufacturing process emits near-zero VOCs
 - Nearly every component can be recycled
- 2.5. Connected
 - Real-time alerts to motorists using connected systems
 - Helps prevent accidents and improve roadway safety
 - Activated at the factory—no user configuration needed
 - Automatically sends data when deployed
 - Optional Fleet Manager portal for additional data
- 2.6. Application
 - Common applications include:
 - Roadwork zones
 - Lane, road and bridge closures
 - Public events

3. DISPLAY

- 3.1. Display panel
 - 3.1.1. Description
 - Weather-resistant cabinet provides a rigid platform for display LEDs
 - 3.1.2. Size
 - 48" x 96" x 3" (122 x 244 x 8cm)
 - 3.1.3. Height
 - When deployed, 84" (213cm) from ground to bottom of display panel
 - 3.1.4. Construction
 - Outer frame constructed of aluminum channel, 3" x 1" x 1/8" thick. Two interior channels add strength and prevent distortion of front and rear panels. All channel joints are welded.
 - Front and rear panels constructed of aluminum sheet, 5052-H32, 0.062" (1.575mm) thick. Panels are riveted and screwed to frame and interior channels.

3.1.5.	Finish	Oven-baked, flat-black (10% gloss), powder-coat finish ensures durability and corrosion protection. Panel assembly is high-pressure phosphate-washed prior to finish coat.	
3.1.6.	Wiring	Weatherproof wiring between solar panel, battery box, control box, and display panel is P-clamped to display panel frame	
3.1.7.	Storage	When lowered for storage and transport, the display panel rests in a support cradle, parallel to the trailer length, locked in place with spring-loaded locking pin	
3.2.	Front lights		
3.2.1.	Description	Display lights are laid out across the front face of the display panel. The layout allows for a variety of arrows and other patterns to appear depending on which lights are lit. The desired pattern is selected by the operator, using the arrow board controls.	
3.2.2.	Type	PAR 46 LED lamp, 5¾" (14.5cm) dia.	
3.2.3.	Wattage	<1.0W per lamp	
3.2.4.	Voltage	8.0Vdc	
3.2.5.	Light output	1425 lux per lamp	
3.2.6.	Reverse-polarity protection	Protects lamps if control box wiring is connected backwards (which sometimes happens after servicing)	
3.2.7.	LEDs	Technology	AllInGaP II (aluminum indium gallium phosphide) technology, T-1¾ size
		Color range	Amber, 590 to 593 nm
		Forward voltage	2.0 to 2.1Vdc @ 20mA
		Temperature limits	Operating temperature, -22 to 185°F (-30 to 85°C)
3.2.8.	Lens	Function	Each lamp has an integrated hex lens that enhances the brightness and angularity of each LED while reducing power consumption
		Material	Acrylic
		Beam angle	Horizontal: 16.8 degrees, ±8.4 degrees Vertical: 9.5 degrees, ± 4.75 degrees Angle determined by 10% of peak candle power (certified by independent testing laboratory)
3.2.9.	Visor	Function	Each lamp is shrouded by a visor that enhances visibility by shading the lamp and preventing glare
		Material	High-impact ABS plastic
		Mounting	Four keyed slots enable visor to be removed from the display panel without removing screws

- 3.2.10. Visibility At least 1 mile (1.6km)
- 3.2.11. Angularity 26.8 degrees @ 105 ft. (32m)
54.0 degrees @ 49 ft. (15m)
Total viewing area, per 2008 NTPEP results
- 3.2.12. Auto-dimming A photocell detects ambient light; the controller adjusts the brightness of the LEDs accordingly, dimming display brightness in darkness, increasing to full brightness in daylight
Photocell is located inside control box, facing downward
- 3.2.13. Replacement Lamps can be replaced in less than two minutes. The only tool needed is a Philips screwdriver.
- 3.3. Rear lights
 - 3.3.1. Description Two indicator lights on the back of the display panel suggest the current arrow board function to an operator located behind the arrow board by flashing a corresponding pattern
 - 3.3.2. Type Sealed 2-diode LED light, surface-mount, 2½" x ¾" (6.6 x 1.9cm) lens
See "Options and Optional Equipment" for rear light options
 - 3.3.3. Wattage 0.9W
 - 3.3.4. Voltage 8.0Vdc
- 3.4. Standards Meets requirements for minimum size, legibility, and number of elements per MUTCD, December 2009 ed., §6F.61, ¶105, Temporary Traffic Control Zone Devices: Arrow Boards
Meets specs for MUTCD Type C

4. CONTROL SYSTEM

- 4.1. Function Allows operator to choose an arrow or other display pattern. Keeps the batteries fully charged while protecting them from deep discharge and overcharging. Maintains display flash-rate and controls automatic dimming. Sends data to the cloud for connected services.
- 4.2. Control box
 - 4.2.1. Location Installed on bracket behind and below display panel
 - 4.2.2. Enclosure Aluminum sheet construction, brushed aluminum finish
Hinged weatherproof cover with slam-latch
Hole in cover accepts customer-supplied padlock

- 4.2.3. Cable protection Molded plastic cover attached to back of control box, protects external wiring connections and can be removed for access to connectors; all wiring has quick-connect plugs
- 4.2.4. Serviceability Entire control box is removable for easy exchange and factory servicing
- 4.3. Control panel
 - 4.3.1. Display switch Toggle switch for turning arrow board display on and off
 - 4.3.2. Display pattern selection Rotary switch; operator simply points the switch at the desired display pattern, which is silkscreened onto the front of the control panel
 - 4.3.3. LED indicators Indicates the following status conditions:
 - Low voltage (battery charging required)
 - Low battery voltage detected, power shutdown occurred
 - Solar charging system is charging batteries
 - Batteries are fully charged
- 4.4. Display patterns
 - 4.4.1. All models All arrow boards can display any of the following 7 patterns (for samples, see Exhibit A):
 - Flashing arrow, left or right 10 lights total
 - 5 lights form arrowhead
 - 5 lights form stem
 - Flashing double arrow 13 lights total
 - 5 lights form each arrowhead
 - 3 lights form stem
 - Flashing four-corner warning 4 lights total
 - 1 light at each corner
 - Flashing caution-bar warning 7 lights form horizontal bar across center of display panel
 - Sequencing stem arrow, left or right 10 lights total
 - 5 lights form arrowhead
 - 5 lights form full stem
 - 1st pulse: 2 far stem lights
 - 2nd pulse: 5 far stem lights
 - 3rd pulse: full arrow shape
 - 4th pulse: blank display

4.4.2. 25-light models In addition to the 7 patterns described above, 25-light arrow boards can also display any of the following 5 patterns (for samples, see Exhibit A):

- | | |
|--|--|
| Sequencing walking arrow, left or right | 10 lights total
5 lights form arrowhead
5 lights form full stem

1st pulse: 2 far stem lights with arrowhead
2nd pulse: 3 far stem lights with arrowhead
3rd pulse: full arrow shape
4th pulse: blank display |
| Sequencing chevron arrows, left or right | 15 lights total
5 lights form each arrowhead

1st pulse: 1 far arrowhead
2nd pulse: 2 far arrowheads
3rd pulse: 3 arrowheads
4th pulse: blank display |
| Alternating diamonds | 16 lights total
8 lights form each diamond

1st pulse: 1 diamond shape on left
2nd pulse: 1 diamond shape on right |

4.5. Electronics

- | | |
|------------------------------------|--|
| 4.5.1. Location | Inside control box |
| 4.5.2. Temperature limits | Operating temperature: -40 to 176°F (-40 to 80°C) |
| 4.5.3. Flash rate | 30 to 40 per minute, all display patterns |
| 4.5.4. Positive drive circuit | Positive power applied to lamps only when lit
Negative is chassis grounded |
| 4.5.5. Fuse protection | Dual PTC resettable fuses |
| 4.5.6. Reverse-polarity protection | Protects the controller if battery cables are connected backwards (which sometimes happens after servicing) |
| 4.5.7. Low-voltage disconnect | Low-voltage-disconnect circuit engages when battery voltage drops to 11.2Vdc, shutting down power to protect batteries from full discharge |
| 4.5.8. Asset tracker | Factory configured, no user setup needed

Automatically sends arrow board data to connected systems via the cloud

Connected data includes GPS location, display pattern, on/off state, and compass bearing

See “Options and Optional Equipment” for Wanco Fleet Manager option |

5. TRAILER

5.1.	Frame	All welded structural steel
5.2.	Deck	Structural deck adds 350 lb (159kg) to overall weight, creating a low center of gravity and improving stability
5.3.	Fenders	Round, full wheel coverage, bolted to trailer frame, removable and replaceable
5.4.	Tie-downs	One on each front corner of frame, one centered on rear frame
5.5.	Finish	
5.5.1.	Prewash	Assemblies are run through a five-stage, high-pressure phosphate-wash prior to finish coat
5.5.2.	Coating	Frame is coated with oven-baked, safety-orange powder-coat finish to ensure durability and corrosion protection See "Options and Optional Equipment" for color options
5.5.3.	Salt spray resistance	1000 hours (ASTM Method B117) with <1/8" (<3.18mm) creep from scribe
5.5.4.	QUV exposure	500 hours QUV-B (ASTM Method D4587-05) >75% gloss retention
5.6.	Axle assembly	Tubular, 2000 lb. (907.2kg) capacity, 5 on 4.5" B.C. idler hub
5.7.	Springs	Double-eye leaf springs, 1200 lb. (544.3kg) capacity for each spring
5.8.	Tires	ST205/75D15 steel-belted trailer tires, load rating B
5.9.	Drawbar	
5.9.1.	Construction	Telescopes inside receiver sleeve welded under trailer frame. Removable for shipping and for added theft protection if needed. Secures with two 1/2-inch diameter bolts.
5.9.2.	Material	3" (7.62cm) square steel tubing, 3/16" (0.476cm) wall
5.9.3.	Jack	Top-wind swivel, 2000-lb. (907kg) capacity, steel footpad, 10" (25cm) total travel
5.9.4.	Tow hitch	Standard 2-inch ball coupler tow-hitch, SAE Class 2, 3500-lb. (1588kg) capacity. Bolts to drawbar, removable and replaceable. See "Options and Optional Equipment" for tow-hitch options.
5.9.5.	Tow chains	Two high-test proof coil chain assemblies, with "latching" S-hooks for towing. Chains attached to drawbar with quick connectors. Material diameter 0.406" (10.3mm) Working load limit 5400 lbs. (2450kg) Breaking force 16,200 lbs. (72kN)

5.10. Stabilizer legs

5.10.1. Description Four stabilizers, mounted on corners of trailer frame, extend downward from front and rear of trailer at 30-degree angle, increasing length of footprint when deployed

5.10.2. Adjustment Stabilizers slide up and down in sleeves, adjustable in 1" (2.54cm) increments, held in place by 3/8" (0.95cm) wire lock pin. A lanyard ties each pin to the trailer frame.

5.10.3. Material
Leg Perforated 1¾" sq. steel tube, 12ga wall, zinc plated
Footpad 4" x 6" (10 x 15cm) steel, zinc plated, all edges turned up

5.11. Wind resistance Approx. 57mph (91km/h), calculated maximum sustained wind load before overturning, trailer in deployed position supported by four stabilizer legs and one drawbar jack with tires off the ground

5.12. Wiring

5.12.1. Description Wiring to connect tow vehicle and trailer for trailer taillights is installed inside drawbar, with pigtails and connectors at both ends; no crimping required

5.12.2. Trailer plug A sealed, molded, 4-square connector plugs into harness under trailer

5.12.3. Tow-vehicle plug Two-piece assembly with 4-flat molded connector on harness plugs into tow vehicle
Meets SAE J1239
See "Options and Optional Equipment" for tow-vehicle plug options

5.12.4. Protection All trailer wiring encased in UV protective loom, and attached with P-clamp riveted to trailer frame; no exposed wires

5.13. Taillights Two oval-shaped, sealed, LED, combination stop, turn and taillights integrated with fenders

5.14. Reflectors Two amber reflectors, one on the side of each upright
Two red reflectors on rear trailer frame
See "Options and Optional Equipment" for reflective tape

5.15. License plate Lighted license plate holder is mounted under rear of trailer frame

5.16. Tower assembly

5.16.1. Function Display panel is raised and lowered on a telescoping tower

5.16.2. Tower construction Two sections of square steel tubing with the inner section telescoping inside the outer section. The inner section is zinc plated to prevent corrosion.
Nylon guide blocks keep the sections tight, eliminating the need for greasing the tower and preventing dirt from building up on the inner tower section. Dirt would cause performance problems and maintenance issues.

- 5.16.3. Swivel base A steel tubular weldment is bolted to the trailer frame. The outer tower section rotates on a thrust bearing and washers inside the swivel base, reducing rotating friction.
- 5.16.4. Height At fully deployed height, 84" (213cm) from ground to bottom of display panel
- 5.16.5. Height lock Spring-loaded locking pin prevents tower from falling if the winch or cable were to fail. Also locks tower when fully lowered into travel position.
- 5.16.6. Winch assembly Function Hand-operated winch raises and lowers display panel
Capacity 1500 lbs. (680kg)
Brake Safety friction-brake prevents display panel from falling if operator loses grip on winch handle
Cable 1/4" (6.35mm) diameter galvanized aircraft cable
- 5.16.7. Rotation Tower and display panel pivot\ freely and continuously in either direction; tower has no wires connected to trailer that would otherwise restrict rotation
- 5.16.8. Rotation lock Locking pin inserted into horizontal plate mounted to tower prevents tower from rotating
- 5.16.9. Sight tube A sight tube for aiming the display panel in desired direction is mounted to the underside of the display panel frame

6. POWER SYSTEM

- 6.1. Description Electronics powered by batteries, which are charged automatically with integrated solar charging system
- 6.2. Battery box
 - 6.2.1. Function Holds batteries and optional remote charger
 - 6.2.2. Construction Riveted all-steel construction, cover is bolted in place
Removable panel on side of battery box provides access to optional remote charger
All parts powder-coated before assembly
 - 6.2.3. Mounting Bolted to bracket installed on tower frame behind display panel
- 6.3. Batteries
 - 6.3.1. Type Leak- and spill-proof valve-regulated lead acid (VRLA)
See "Options and Optional Equipment" for battery options

6.3.2.	Features	100% maintenance-free Sealed and spill-proof Faster recharge and greater freeze resistance than conventional batteries Smaller and lighter-weight than conventional batteries Contains 80% less lead when compared to conventional batteries
6.3.3.	Quantity	Two
6.3.4.	Voltage	12Vdc each
6.3.5.	Weight	12.5 lbs. (6kg) each
6.3.6.	Capacity	36 Ah total @ 12Vdc
6.4.	Solar	
6.4.1.	Panels	One high-efficiency multi-crystal photovoltaic solar module
6.4.2.	Location	Above display panel, no shadowing effect on any trailer component. Solar panel lies flat; rises and rotates with display panel.
6.4.3.	Power	50W See "Options and Optional Equipment" for solar options
6.4.4.	Current	2.89A max. system current 3.22A open short-circuit current
6.4.5.	Voltage	17.3Vdc max. 21.6Vdc open short-circuit voltage
6.4.6.	Regulation	Solar panels regulated by arrow board controller
6.4.7.	Security	Solar panel bolted to mounting frame with security screws and special security nut

7. DIMENSIONS & WEIGHT

7.1. Dimensions

*inches
(cm)*

Travel position

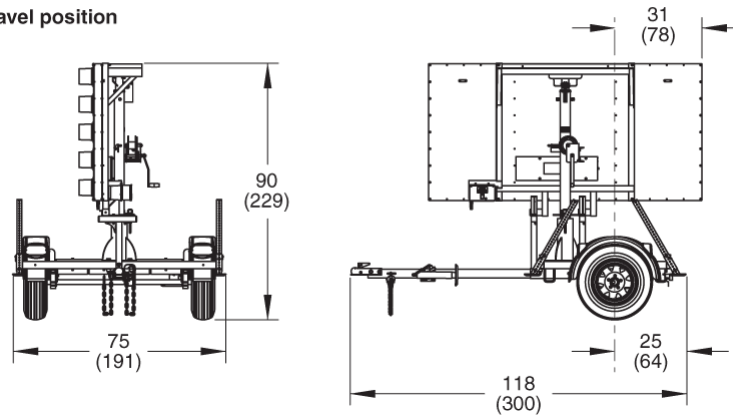

Deployed

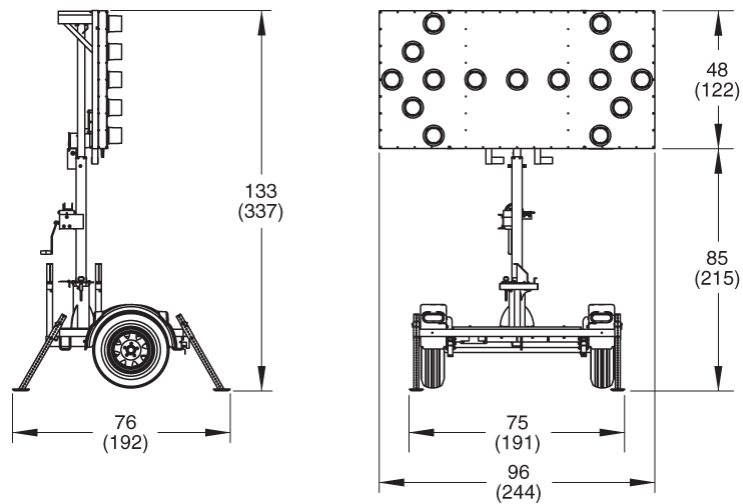

7.2. Weight

Approx. 1250 lbs. (567kg)

8. OPTIONS AND OPTIONAL EQUIPMENT

8.1. Tow hitch

- 8.1.1. Combo hitch Combo-hitch for 2-inch ball and 2 1/2-inch ID x 1-inch cross-section pintle hook
- 8.1.2. Lunette ring Options Standard ring for 2 1/2-inch ID x 1-inch cross-section pintle hook
Heavy-duty ring for 3-inch ID x 1 5/8-inch cross-section pintle hook

8.2. Trailer plug

A variety of adapters are available to allow the standard connector to plug into nearly any tow vehicle receptacle. Contact factory for details.

8.3. Leveling jacks

Four swivel jacks replace stabilizer legs, mounted on corners of trailer frame

8.4. Power

8.4.1. Additional batteries

For geographic locations with less solar charging potential or colder weather, and for applications that require year-round charging, add batteries for greater capacity

Options One additional VRLA 12Vdc battery, 18Ah additional capacity

8.4.2. Battery charger

Function Plugs into a standard AC power source to recharge batteries if battery voltage drops due to lack of sun for automated solar charging system

Type 12-volt battery charger

Location Inside battery box

Smart charger Three-stage smart-charging circuit keeps batteries fully charged and will not overcharge batteries, which help ensure the longest possible battery life

Output capacity 2A

Output voltage 14.4Vdc nominal
13.0Vdc nominal float voltage

Input voltage 90 to 132Vac, standard two-prong plug

Frequency 50 to 60 Hz

8.4.3. Solar

For geographic locations with smaller solar charging potential, and for applications that require a year-round charging system, additional solar power is available

Options include 85W, 100W solar arrays; contact factory for details

8.5. Reflective tape

Reflective red-and-white conspicuity tape across rear trailer frame for increased visibility

8.6. Finish color

Specify power-coat color and, if applicable, color scheme

8.7. Manual dimming

Substitute control box with manual dimming control for standard control box





8.8. Rear lights

Replace standard rear lamps with PAR 36 LED lamps, 4.5" (11.5cm) dia.





8.9. Wanco Fleet Manager	Description	Web-based service provides online access to connected arrow boards remotely and wirelessly
	Features	Remote access with easy-to-use dashboard View GPS location and compass bearing on detailed map View arrow board display pattern, display on/off state, voltages and alarms View trailer stance, including tip-over status Set up and receive system alerts via text or email Execute remote command to set 4-corner-caution pattern or blank the display (available only in some operating modes) View system performance Review operation history log and audit trail
	System requirements	Modern standards-compliant Web browser with JavaScript enabled A platform that supports one of these browsers (smartphone, tablet, or computer) Internet connection

EXHIBIT A: DISPLAY PATTERNS

Flashing patterns

Pulse 1	Pulse 2	
		Flashing arrow, left or right
		Flashing double arrow
		Flashing four-corner warning
		Flashing caution-bar warning

Sequential patterns

Pulse 1	Pulse 2	Pulse 3	Pulse 4	
				Sequencing arrow, left or right
				Sequencing stem arrow, left or right*
				Sequencing chevron arrows, left or right*
				Alternating diamonds*

**Available only on 25-light arrow board models*