

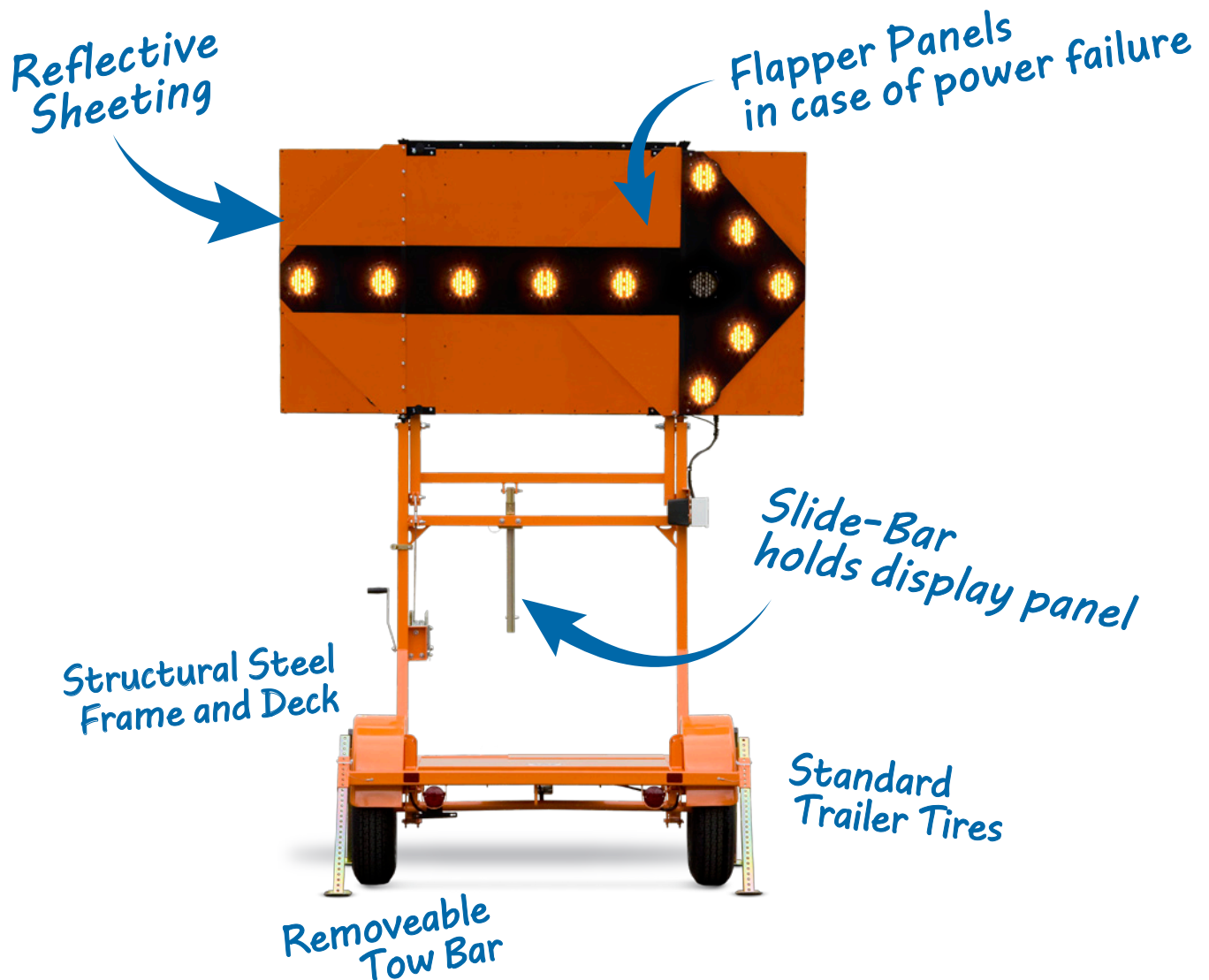

# Wanco® 15-Light Portable W|ECO® Arrow Board

- Super-bright LED display
- 7 display patterns
- Energy efficient eco-friendly operation
- Large display is MTO approved
- Maintenance-free batteries



## Features

### Environmental

- Maintenance-free batteries
- Consumes 80% less power than other solar arrow boards
- Smaller batteries have 80% less lead content
- Sealed batteries will not leak or spill
- Decreased charging time saves energy and downtime
- Manufacturing process emits near-zero VOCs
- Nearly every component can be recycled

### Functional

- High-output amber LEDs legible up to 1 mile (1.6 km)
- Fully MTO compliant
- 15 lamps with 7 arrow display modes
- Easy to operate and maintain
- Heavy-duty hand-winch with safety brake allows one person to raise display panel
- Single locking device holds display panel in place while operating and during transport
- Controller located safely away from traffic
- Weather-resistant control box cover, lockable slam-latch
- Control box outputs have short-circuit protection, helping prevent blown transistors
- Positive-drive voltage system applies power to lamps only when lit
- Power system includes resetting dual circuit breakers, reverse polarity protection, and low-voltage disconnect
- Solar charging system features solid state voltage regulator with charge indicator
- Arrow display has automatic and manual dimming, with flash rates of 30 to 40 per minute
- In travel position, unique design supports board without rear braces, reducing possibility of damage during transport
- Durable powder-coat finish resists the elements
- Meets MUTCD
- NTPEP tested

## Brief specifications

### Display

Lights	Amber LEDs, 15 on front, 2 on back
Legibility	1 mile (1.6km) max. legible distance
Winch	Hand-operated, raises and lowers display
Standards	Meets MUTCD Type C, MTO-approved

### Construction

Trailer	All welded structural steel
Display cabinet	Aluminum sheet and welded channels
Finish	Powder-coated and oven-baked
Axle assembly	2000 lb. (907kg) capacity with 5-on-5.5" B.C. idler hub
Tires	ST205/75D15 trailer tires

### Power\*

Batteries	Two leak- and spill-proof, valve-regulated lead acid (VRLA)
Battery capacity	48 Ah total
Battery voltage	12 Vdc
Solar panel	55 W

\*Standard power; many options available. Contact factory for details.

### Dimensions

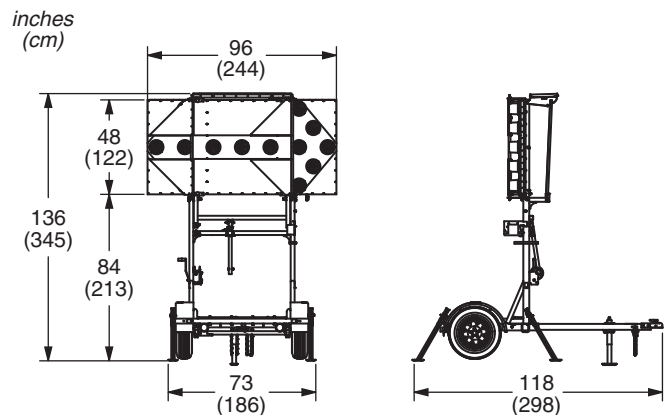

Travel height: 91 in. (230cm)

### Weight

Approx. 1000 lbs. (453kg)

Due to Wanco's commitment to continuous improvement of our products, all information is subject to change without notice. Wanco and the Wanco logo are registered trademarks of Wanco Inc.



**WANCO INC.**  
5870 Tennyson Street  
Arvada, Colorado 80003  
800-972-0755  
303-427-5700  
303-427-5725 fax  
[www.wanco.com](http://www.wanco.com)