

# X-MARKER™ L-893(L) RUNWAY CLOSURE MARKER

MODEL WTRC  
PRODUCT SPECIFICATIONS | JUNE 2021

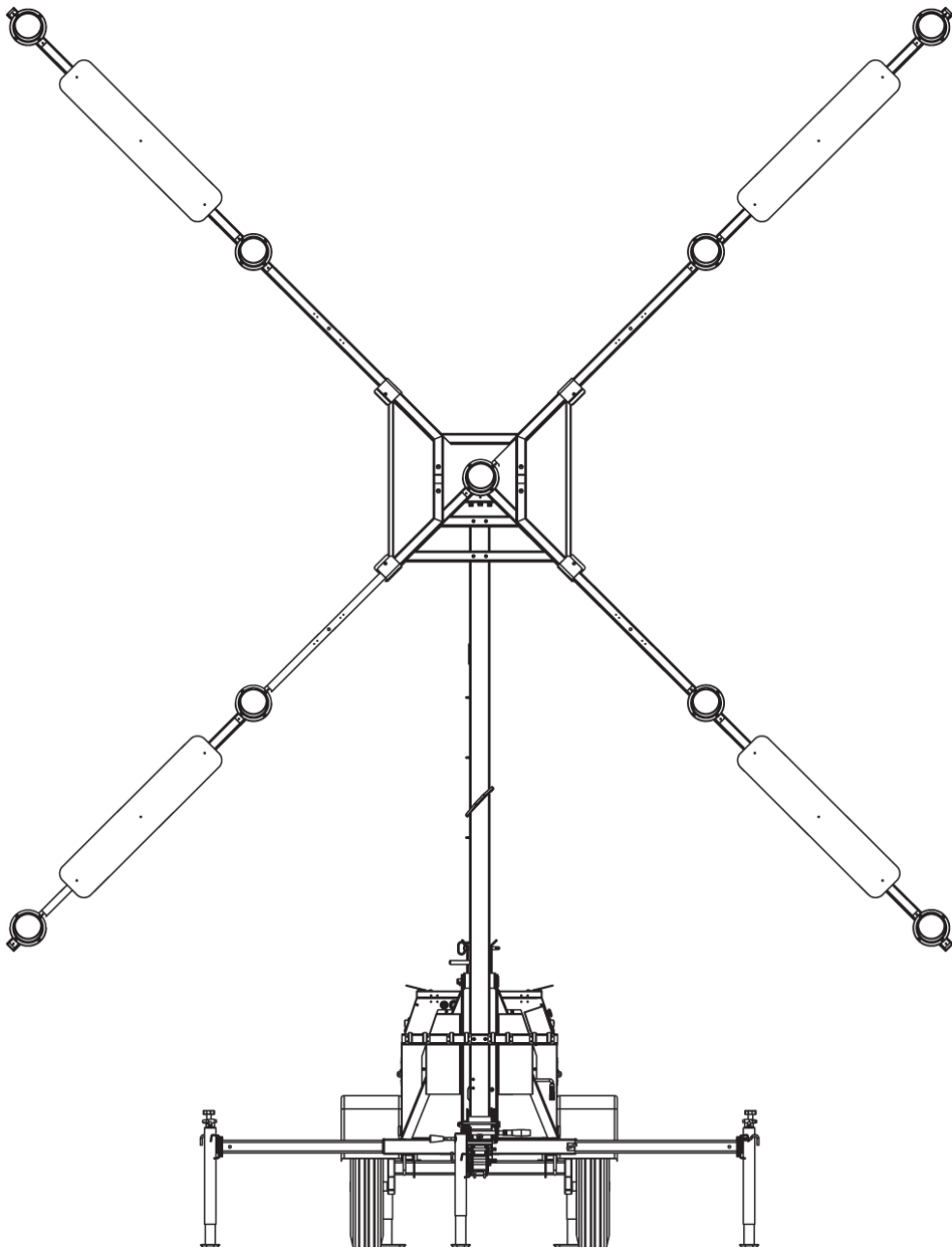

## 1. SYSTEM

- 1.1. Description
- The Wanco X-Marker™ L-893(L) Runway Closure Marker is a lighted visual aid for indicating to airplane pilots that an airport runway is closed. Designed and certified in accordance with FAA requirements, its flashing lights can be seen both day and night from miles away, clearly discernable as a giant “X” and distinguishable from other lighted visual devices used at airports, signifying that the runway is not open for landings. The X-Marker trailer is easy to transport, and can be deployed by one person in less than five minutes.
- The “X” shape comprises nine lights on four independent arms and a mast. When deployed, the mast tilts upward to nearly vertical, and the “X” is centered at the top of the mast. For transport and storage, the mast tilts downward and the arms pivot together. The entire assembly lies flat when stowed, held in place by support brackets and lock-pins.
- Each arm includes two high-efficiency LED light fixtures, with one additional light fixture located at the center of the “X.” LEDs provide highly directional light distribution, resulting in high luminosity and low power consumption.
- System power is provided by a diesel engine. The system can run continuously for up to a week without intervention or refueling. Backup batteries are charged by the engine and continue to power the lights if the engine shuts down. Can also connect to shore power.
- A weather-resistant enclosure houses the power system and has two side doors for easy access. A hinged top panel provides greater access when maintenance is required. The side doors may be opened while the maintenance panel is raised. An optional fluid-containment system protects against leaks, spills, and drips.
- 1.2. Model
- WTRC X-Marker, FAA L-893(L) lighted visual aid to indicate temporary runway closure
- 1.3. Temperature limits
- |           |  |
|-----------|--|
| Operating | 0 to 140°F (–18 to 60°C) on engine power<br>–40 to 140°F (–40 to 60°C) on shore power<br>See “Options and Optional Equipment” for cold-weather options |
| Storage   | –40 to 185°F (–40 to 85°C)   |
- 1.4. Humidity limits
- Conformal coating rated to 95% relative humidity
- 1.5. Wind load
- Exceeds FAA requirements for minimum wind speed
- 1.6. Run time
- With engine, approximately 120 hours (5 days) continuous operation on one tank of fuel  
On batteries only, after engine shutdown, up to 24 hours depending on battery condition
- 1.7. Standards
- Certified for use at FAA-regulated airports in accordance with the following documents of the US Department of Transportation, Federal Aviation Administration:
- FAA AC 150/5345-55A, “Specification for L-893, Lighted Visual Aid to Indicate Temporary Runway Closure”
- FAA EB67D, “Light Sources Other Than Incandescent and Xenon For Airport and Obstruction Lighting Fixtures”
- FAA AC 150/5345-53D, “Airport Lighting Equipment Certification Program”
- FAA Addendum to AC 150/5345-53D

## 2. FEATURES

- 2.1. Transport
  - Extremely portable, can be towed by most vehicles
  - Compact trailer is easy to maneuver
  - Cradles with locking pins hold display arms in place during transport
- 2.2. Setup
  - Heavy-duty hand-winch allows one person to easily raise and lower “X” assembly
  - Lock-pins hold the assembly in place during operation
  - Two outriggers and five leveling jacks provide stability
  - Full deployment by one person takes less than five minutes
- 2.3. Operation
  - Fully enclosed steel equipment-bay protects controls, power system, and other components from the elements
  - Two gull-wing doors with latches provide access to controls, fuel tank, engine, and electronics
  - Locking door latches protect equipment bay from unauthorized access
  - Control panel features elapsed hour meter, engine indicator lights, and brightness-selection switch
  - Manually activated high-power operating mode melts snow and ice from lights
- 2.4. Lights
  - High-efficiency LED lights provide bright, highly directional light
  - Lights are instant-on and immediately at full intensity
  - Flashing front-facing lights are visible for miles, day or night, even in poor weather
  - Flashing rear-facing indicator lights allow operator to see the equipment is operating
- 2.5. Power system
  - Ultra-quiet industrial diesel engine, 3-cylinder and water-cooled
  - Energy-efficient operation results in extraordinarily long run times
  - Extra-large polypropylene fuel tank shows fuel-level at a glance, no need for fuel gauge
  - Fuel tank has wide filler neck for convenience
  - Automatic engine-shutdown system protects engine from damage due to low oil pressure and high coolant temperature
  - Backup batteries continue to power lights if engine fuel runs out
  - System can be connected to shore power or portable power generator
- 2.6. Maintenance
  - 50,000-hour LED lifespan reduces maintenance by virtually eliminating the need for replacement
  - Hinged maintenance panel provides unimpeded access to engine, generator and electrical components
  - Durable powder-coat finish resists the elements
  - Standard trailer tires
  - Heavy-duty bolt-on fenders can be replaced if damaged
- 2.7. Applications
  - Lighted visual indication of temporary closure of airport runway
  - Can also be used for airport taxiways

### 3. "X" ASSEMBLY

- 3.1. Light arms Four parallel arms pivot at one end to form "X" shape, two outer arms pivoting 135 degrees and two inner arms pivoting 45 degrees.
- Each arm has two light fixtures attached to its front side and one indicator light attached to its back side. The front facing lights are located at the outer end and middle of each arm. The rear-facing indicator light is at the outer end. A single, front-facing light fixture is located at the center of the "X" assembly. On each arm, between its front-facing lights, a wide flat panel is attached to each arm for increased visibility.
- Support brackets with lock-pins hold arms in place when deployed and stored.
- 3.2. Mast Light arms are attached to a tilting mast that lies flat for storage and pivots upward to 5 degrees off vertical (85 degrees from horizontal) when deployed for operation
- A spring-loaded lock-pin engages automatically to hold the mast assembly in place when fully raised
- 3.3. Material Light arms and mast are structural steel tubing
- Visibility panels on arms are sheet aluminum
- 3.4. Finish
- |                       |   |
|-----------------------|---|
| Prewash               | Assemblies are run through a five-stage, high-pressure phosphate-wash prior to finish coat  |
| Coating               | Light arms and flat panels are coated with oven-baked "aviation yellow" powder-coat finish to ensure durability and corrosion protection (color per FAA specifications) |
| Salt spray resistance | 1000 hours (ASTM Method B117) with $< \frac{1}{8}$ " ( $< 3.18$ mm) creep from scribe   |
| Q.U.V. exposure       | 500 hours QUV-B (ASTM Method D4587-05) $> 75\%$ gloss retention   |
- 3.5. Front-facing lights
- 3.5.1. Lamp type High-efficiency LEDs
- 3.5.2. Number of lights Nine LED light fixtures
- 3.5.3. Luminosity 6000 lumens per fixture
- 54,000 lumens total
- 3.5.4. Effective intensity Exceeds all FAA requirements for minimum effective intensity at beam center
- |       |                               |
|-------|-------------------------------|
| Day   | $> 150,500$ cd at beam center |
| Night | $> 6000$ cd at beam center    |
- 3.5.5. Color 5000K daylight

- 3.5.6. Wattage 44 watts per fixture when on, zero watts when off  
397 watts total
- 3.5.7. Voltage 24Vdc
- 3.5.8. Flash rate 2.5 sec on, 2.5 sec off
- 3.6. Rear-facing lights
  - 3.6.1. Function Four rear-facing lights flash on and off when front lights are flashing, indicating to tower personnel or an operator located behind the unit that the unit is operational
  - 3.6.2. Type Sealed 2-diode LED light, surface-mount, 2½" x ¾" (6.6 x 1.9 cm) lens
  - 3.6.3. Wattage 0.1W
  - 3.6.4. Voltage 24Vdc
- 3.7. Winch assembly
  - 3.7.1. Function Hand-operated winch raises and lowers tilting mast
  - 3.7.2. Capacity 2500 lb (1133 kg)
  - 3.7.3. Pulleys Double pulley system reduces cable tension and winch load by 50%
  - 3.7.4. Brake Safety friction-brake prevents mast from falling if operator loses grip on winch handle
  - 3.7.5. Cable 1/4" (6.35 mm) diameter galvanized aircraft cable

#### 4. CONTROL SYSTEM

- 4.1. Function Allows the operator to start and stop the engine, and turn lights on and off. Regulates the flash rate and automatic dimming of lights. Keeps the batteries fully charged while protecting them from deep discharge and overcharging.
- 4.2. Control box
  - 4.2.1. Location Inside equipment bay on left (driver's) side of trailer
  - 4.2.2. Enclosure Aluminum sheet construction, powder-coated for durability
  - 4.2.3. Serviceability Hinged control panel with single fastener provides access to interior of control box  
Entire control box is removable for servicing
- 4.3. Control panel
  - 4.3.1. Power switch Toggle switch provides selection of light function:  
On at full brightness  
On with automatic photocell-controlled brightness  
Off

- 4.3.2. LED indicators            Indicates engine status conditions:
  - High-temperature shutdown
  - Low oil pressure
  - Attention required
- 4.3.3. Key switch                Turns engine on and off
- 4.3.4. Hour meter                Displays cumulative engine operating hours for routine maintenance
- 4.4. Operating modes
- 4.4.1. Normal                    Normal operation
  - Normal operating mode is user-controlled via control panel
- 4.4.2. High-power                Maximum continuous power is applied to lights, increasing their temperature for melting snow and ice accumulation on the light fixtures; normal operation resumes after one hour
  - High-power mode is user-initiated with rapid sequential movement of power switch
- 4.4.3. Fail-safe                 Lights remain on continuously
  - Fail-safe circuit engages automatically in the event of control system malfunction
- 4.4.4. Low-voltage disconnect            System shuts down power to protect batteries from full discharge; lights strobe at ~2% duty cycle
  - Low-voltage-disconnect circuit engages when battery voltage drops to 21.48Vdc

## 5. TRAILER

- 5.1. Frame                        All welded structural steel
- 5.2. Fenders                     Rectangular Jeep-style fenders, full wheel coverage, bolted to trailer enclosure, removable and replaceable
- 5.3. Finish
- 5.3.1. Prewash                    Assemblies are run through a five-stage, high-pressure phosphate-wash prior to finish coat
- 5.3.2. Coating                    Frame is coated with oven-baked, flat black powder-coat finish; arms are coated yellow to ensure durability and corrosion protection
  - See “Options and Optional Equipment” for color options
- 5.3.3. Salt spray resistance    1000 hours (ASTM Method B117) with <math>\frac{1}{8}</math>” (<math>< 3.18 \text{ mm}</math>) creep from scribe
- 5.3.4. Q.U.V. exposure        500 hours QUV-B (ASTM Method D4587-05) >75% gloss retention
- 5.4. Axle assembly              2200 lb (998 kg) capacity, 5 on 4.5” B.C. idler hub
- 5.5. Springs                      Double-eye leaf springs

- 5.6. Tires ST185/80D13 steel-belted trailer tires, load rating D
- 5.7. Drawbar
  - 5.7.1. Construction Telescopes inside receiver sleeve welded under trailer frame, secured with two M14 bolts
  - 5.7.2. Material 3" (7.62 cm) square steel tubing, 3/16" (0.476 cm) wall
  - 5.7.3. Jack Side-wind swivel, 2000 lb (907 kg) capacity, steel footpad, 10" (25 cm) total travel
  - 5.7.4. Tow hitch Combo-hitch for 2-inch ball and 2½-inch pintle hook; bolts to drawbar  
See "Options and Optional Equipment" for tow-hitch options
  - 5.7.5. Tow chains Two high-test proof coil chain assemblies, with "latching" S-hooks for towing. Chains attached to drawbar with quick connectors.
    - Material diameter 0.406 in (10.3 mm)
    - Working load limit 5400 lb (2450 kg)
    - Breaking force 16,200 lb (72 kN)
- 5.8. Jacks Four stabilizers, mounted on corners of trailer frame
- 5.9. Outriggers Two telescoping outriggers (jack extensions) at front corners of the trailer, expand trailer width and add stability when deployed
- 5.10. Taillights Two oval, sealed, combination stop, turn and taillights in rear panel of equipment bay; each light held in place and sealed with snap-in rubber grommet
- 5.11. License plate License plate holder with light is mounted on rear panel of equipment bay
- 5.12. Reflectors Four reflectors on sides of equipment bay: two red at rear, and two amber at front
- 5.13. Wiring
  - 5.13.1. Trailer plug A sealed, molded, 4-square connector plugs into harness under trailer
  - 5.13.2. Tow-vehicle plug Two-piece assembly with 4-flat molded connector on harness plugs into tow vehicle  
Meets SAE J1239  
See "Options and Optional Equipment" for tow-vehicle plug options
  - 5.13.3. Protection All trailer wiring encased in protective sheathing, attached with P-clamps riveted to trailer frame; no exposed wires





**7. DIMENSIONS & WEIGHT**

7.1. Dimensions *inches (cm)*

**Travel Position**

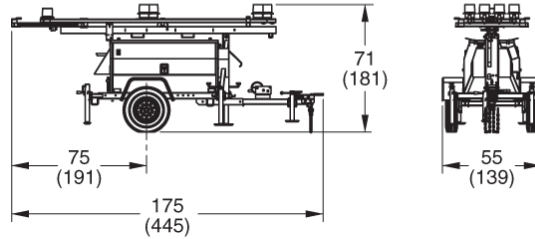

**Deployed**

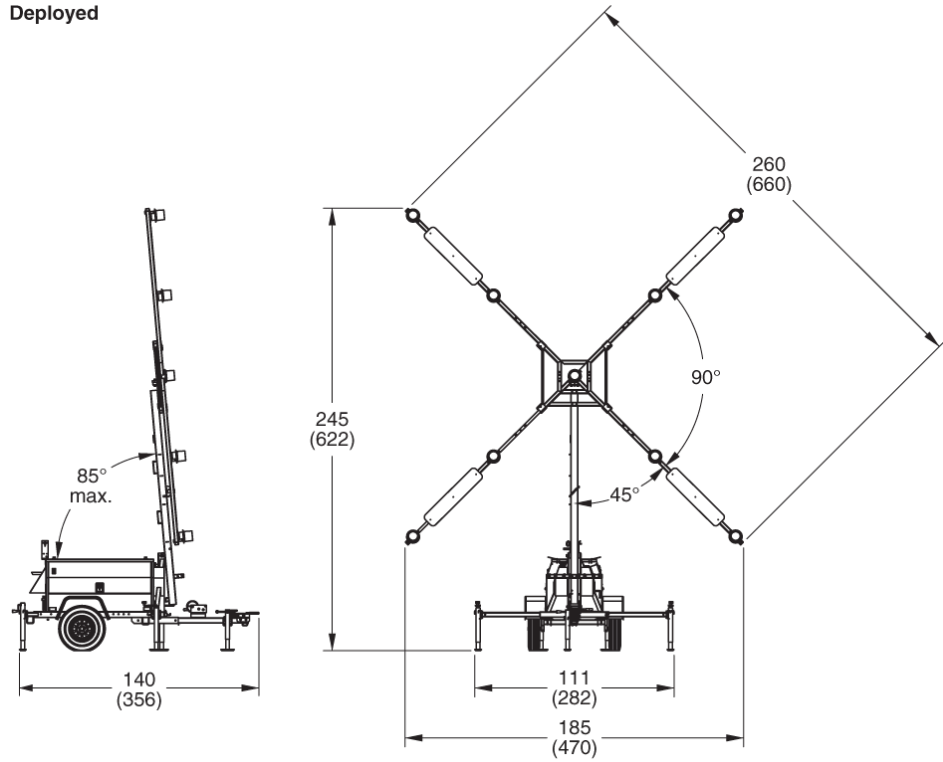

7.2. Operating weight **Approx. 1980 lbs. (898kg)**

## 8. OPTIONS AND OPTIONAL EQUIPMENT

### 8.1. Transport options

- 8.1.1. Torsion axle            Replace standard axle assembly and springs with torsion axle  
Tubular, 2800 lb (1270 kg) capacity, 5 on 4.5" B.C. idler hub
- 8.1.2. Tow hitch              Replace standard tow hitch with optional hitch  
Options    2-inch ball coupler tow hitch  
Standard lunette ring for pintle hook, 2½" ID x 1" cross-section  
Heavy-duty lunette ring for pintle hook, 2½" ID x 1½" cross-section
- 8.1.3. Tow-vehicle plug      Many types of plugs available, prewired at the factory; contact factory for details
- 8.1.4. Tandem tow package      Allows one vehicle to tow two trailers at the same time  
Includes rear tow hitch: universal hitch for 2-inch ball coupler and pintle hook
- 8.1.5. Forklift channels      Oversized forklift channels installed under frame, all-welded construction

### 8.2. Power system options

- 8.2.1. AGM batteries            Replace deep-cycle batteries with top-of-the-line absorbed glass mat (AGM) batteries  
Features    100% maintenance-free  
Sealed and spill-proof  
Faster recharge and greater freeze resistance than conventional batteries  
Contains less lead than conventional batteries  
Option      Two 4D AGM 12Vdc batteries, 400Ah total capacity  
Weight      Approx. 160 lbs. (72kg) each
- 8.2.2. Emergency engine stop      Large emergency-stop button on exterior of equipment bay for quick, manual engine shutdown

### 8.3. Performance options

- 8.3.1. Cold weather package      Extends low operating temperature to –20°F (–29°C).  
Includes oil pan heater, block heater, and battery blanket for improved starting in cold climates. Components are plugged into a 110Vac receptacle inside the equipment bay. The receptacle includes a pigtail that plugs into shore power. Industrial extension cable must be user-supplied.
- 8.3.2. Polar weather package      Extends low operating temperature to –40°F (–40°C).  
Includes everything in cold weather package plus a bottom panel to fully enclose the equipment cabinet, interior cabinet insulation, and a sensor-controlled variable-speed electric fan for improved engine performance in extreme temperatures.

**8.4. Additional options**

- |        |                          |   |
|--------|--------------------------|---|
| 8.4.1. | Fluid containment system | Integral fluid-containment pan holds 110% of system fluids, eliminating the need for an external containment sump<br><br>Includes drain plug at rear of containment pan                   |
| 8.4.2. | Flashing beacon          | Adds flashing beacon to trailer exterior, which activates as a visual signal for low fuel, engine shutdown, and (if equipped) active fluid containment                                    |
| 8.4.3. | Protective cover         | Protective cover for the cabinet, arms, and lights<br><br>Provides protection from dust and dirt when the system is not in use, and eliminates the accumulation of snow and ice in winter |
| 8.4.4. | Finish color             | Specify powder-coat color and, if applicable, color scheme  |