

W|ECO® FOLDING ARROW-BOARD TRAILERS

MODEL WTSP
PRODUCT SPECIFICATIONS | APRIL 2024

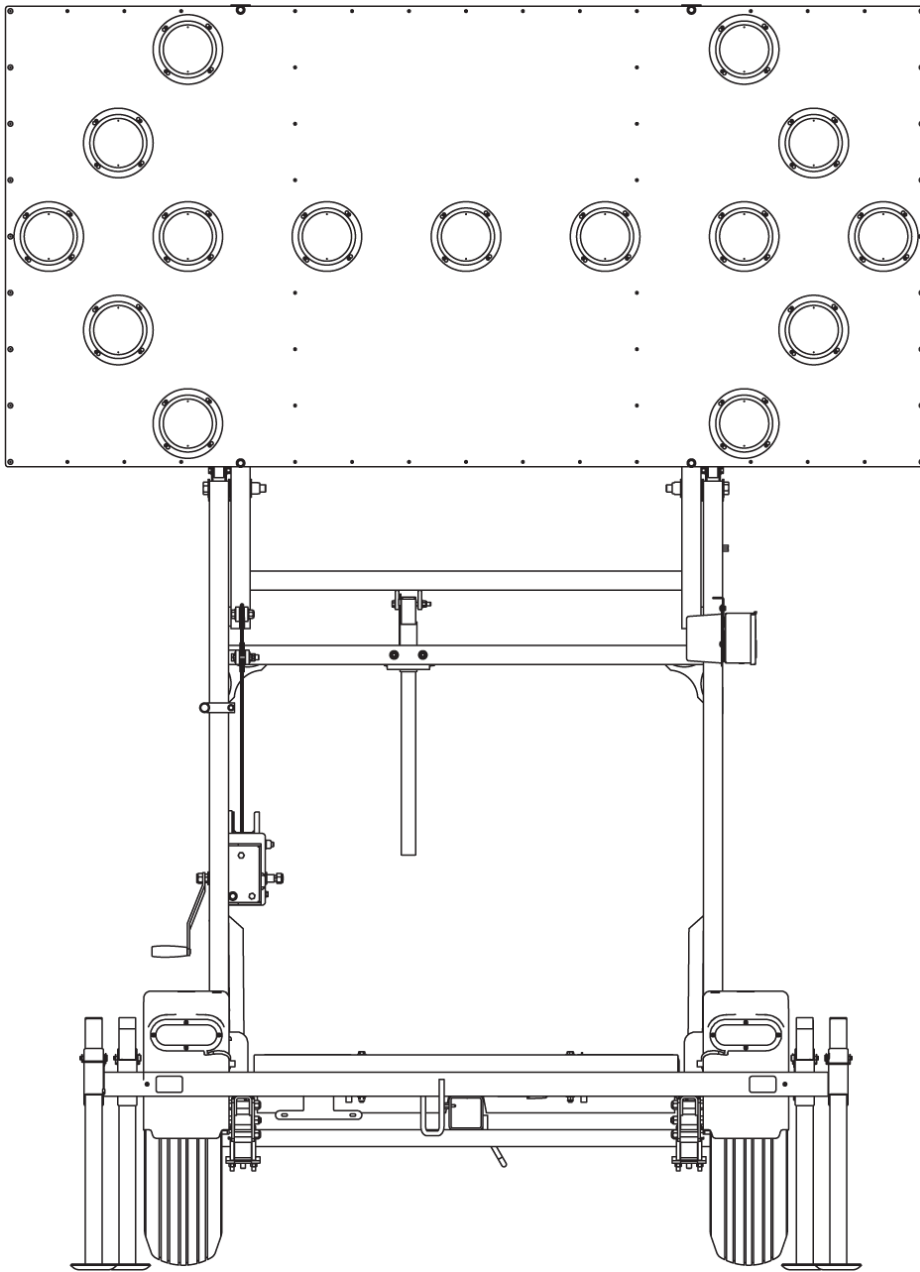

1. DESCRIPTION

- 1.1. Description
- Arrow boards direct traffic by flashing a brightly lit arrow pattern on a large, highly visible display panel. Wanco® Arrow Board Trailers are portable and self-powered, requiring no permanent installation or wiring. Arrows and other patterns are selected by the user.
- Wanco Folding Arrow Boards features a display panel that pivots up to the vertical position when deployed, and down to the horizontal position for transport. The display is locked in place with a single support for ease of use.
- Wanco Arrow Boards feature W|ECO® technology, a highly efficient power system. With Wanco's exclusive LED lamps and small, eco-friendly batteries, W|ECO arrow boards are extremely energy-efficient without sacrificing performance. Power is provided by batteries, which are charged by an automated solar charging system. With sufficient sunlight, W|ECO arrow boards can run indefinitely without intervention.
- Wanco Arrow Boards are also connected to the cloud. Connected Arrow Boards send digital alerts to warn drivers of hazards in advance, helping to increase driver awareness, improve roadway safety and reduce work zone fatalities.
- 1.2. Models
- 1.2.1. WTSP-LSA Arrow-board trailer with 15-light display panel
- 1.2.2. WTSP-LSAC Arrow-board trailer with 25-light display panel

2. FEATURES

- 2.1. Operation
- High-output amber LEDs
 - Selection of arrow and other display patterns
 - Easy to operate and maintain
 - Heavy-duty hand-winch with safety brake allows one person to raise board
 - Single locking device holds arrow board in place while operating and during transport
 - Controller located safely away from traffic
 - Weather-resistant control box cover has lockable slam-latch
 - Control box outputs have short-circuit protection, helping prevent blown transistors
 - Arrow display has automatic dimming
 - Stabilizer legs raise tires off the ground to provide stability in high wind
 - Meets MUTCD
- 2.2. Power system
- Energy-efficient operation results in long run times
 - Solar panels charge batteries automatically without intervention
 - Charging system shuts down when batteries are fully charged, preventing damage
 - Unique system allows battery charging with solar panels or commercial power
 - Power system includes reverse polarity protection and low-voltage disconnect circuit
 - Controller has resettable fuses
 - Solar charging system features solid state voltage regulator with charge indicator

- 2.3. Maintenance
 - Maintenance-free batteries
 - Durable powder-coat finish resists the elements
 - In travel position, unique design supports board without rear braces, reducing possibility of damage during transport or storage
 - Lamps and visors are easily replaced
 - Standard trailer tires
 - Heavy-duty bolt-on fenders can be replaced if damaged
- 2.4. Environmental
 - Consumes 80% less power than traditional solar arrow boards
 - Small batteries have 80% less lead content
 - Sealed batteries will not leak or spill
 - Decreased charging time saves energy and downtime
 - Manufacturing process emits near-zero VOCs
 - Nearly every component can be recycled
- 2.5. Connected
 - Real-time alerts to motorists using connected systems
 - Helps prevent accidents and improve roadway safety
 - Activated at the factory—no user configuration needed
 - Automatically sends data when deployed
 - Optional Fleet Manager portal for additional data
- 2.6. Application

Common applications include:

 - Roadwork zones
 - Lane, road and bridge closures
 - Public events

3. DISPLAY

3.1. Display panel

3.1.1. Description Weather-resistant cabinet provides a rigid platform for LED lamps

3.1.2. Size 48" x 96" x 3" (122 x 244 x 8cm)

3.1.3. Height When deployed, 84" (213cm) from ground to bottom of display panel

3.1.4. Construction Outer frame constructed of aluminum channel, 3" x 1" x 1/8" thick. Two interior channels add strength and prevent distortion of front and rear panels. All channel joints are welded.

Front and rear panels constructed of aluminum sheet, 5052-H32, 0.062" (1.575mm) thick. Panels are riveted and screwed to frame and interior channels.

3.1.5. Finish Oven-baked, flat-black (10% gloss), powder-coat finish ensures durability and corrosion protection. Panel assembly is high-pressure phosphate-washed prior to finish coat.

3.1.6.	Wiring	Weatherproof wiring between solar panel, control box, and display panel is P-clamped to trailer frame	
3.1.7.	Storage	When lowered for storage and transport, the display panel is held in place without rear braces. As a result, the panel never strikes another surface during transport, eliminating damage that might otherwise occur (such as abrasion, deformation, and warping).	
3.2.	Front lights		
3.2.1.	Description	Display lights are laid out across the front face of the display panel. The layout allows for a variety of arrows and other patterns to appear depending on which lights are lit. The desired pattern is selected by the operator, using the arrow board controls.	
3.2.2.	Type	PAR 46 LED lamp, 5¼" (14.5cm) dia.	
3.2.3.	Wattage	<1.0W per lamp	
3.2.4.	Voltage	8.0Vdc	
3.2.5.	Light output	1425 lux per lamp	
3.2.6.	Reverse-polarity protection	Protects lamps if control box wiring is connected backwards (which sometimes happens after servicing)	
3.2.7.	LEDs	Technology	AllInGaP II (aluminum indium gallium phosphide) technology, T-1¼ size
		Color range	Amber, 590 to 593 nm
		Forward voltage	2.0 to 2.1Vdc @ 20mA
		Temperature limits	Operating temperature, -22 to 185°F (-30 to 85°C)
3.2.8.	Lens	Function	Each lamp has an integrated hex lens that enhances the brightness and angularity of each LED while reducing power consumption
		Material	Acrylic
		Beam angle	Horizontal: 16.8 degrees, ±8.4 degrees Vertical: 9.5 degrees, ± 4.75 degrees Angle determined by 10% of peak candle power (certified by independent testing laboratory)
3.2.9.	Visor	Function	Each lamp is shrouded by a visor that enhances visibility by shading the lamp and preventing glare
		Material	High-impact ABS plastic
		Mounting	Four keyed slots enable visor to be removed from the display panel without removing screws

- 3.2.10. Visibility At least 1 mile (1.6km)
- 3.2.11. Angularity 26.8 degrees @ 105 ft. (32m)
54.0 degrees @ 49 ft. (15m)
Total viewing area, per 2008 NTPEP results
- 3.2.12. Auto-dimming A photocell detects ambient light; the controller adjusts the brightness of the LEDs accordingly, dimming display brightness in darkness, increasing to full brightness in daylight
Photocell is located inside control box, facing downward
- 3.2.13. Replacement Lamps can be replaced in less than two minutes. The only tool needed is a Philips screwdriver.
- 3.3. Rear lights
 - 3.3.1. Description Two indicator lights on the back of the display panel suggest the current arrow board function to an operator located behind the arrow board by flashing a corresponding pattern
 - 3.3.2. Type Sealed 2-diode LED light, surface-mount, 2½" x ¾" (6.6 x 1.9cm) lens
See "Options and Optional Equipment" for rear light options
 - 3.3.3. Wattage 0.9W
 - 3.3.4. Voltage 8.0Vdc
- 3.4. Standards Meets requirements for minimum size, legibility, and number of elements per MUTCD, December 2009 ed., §6F.61, ¶105, Temporary Traffic Control Zone Devices: Arrow Boards
Meets specs for MUTCD Type C
- 4. CONTROLLER**
 - 4.1. Function Allows operator to choose an arrow or other display pattern. Keeps the batteries fully charged while protecting them from deep discharge and overcharging. Maintains display flash-rate and controls automatic dimming. Sends data to the cloud for connected services.
 - 4.2. Control box
 - 4.2.1. Location Right (curb-side) upright of trailer frame
 - 4.2.2. Enclosure Aluminum sheet construction, brushed aluminum finish
Hinged weatherproof cover with slam-latch
Hole in cover accepts customer-supplied padlock

- 4.2.3. Cable protection Molded plastic cover attached to back of control box, protects external wiring connections and can be removed for access to connectors; all wiring has quick-connect plugs
- 4.2.4. Serviceability Entire control box is removable for easy exchange and factory servicing
- 4.3. Control panel
 - 4.3.1. Display switch Toggle switch for turning arrow board display on and off
 - 4.3.2. Display pattern selection Rotary switch; operator simply points the switch at the desired display pattern, which is silkscreened onto the front of the control panel
 - 4.3.3. LED indicators Indicates the following status conditions:
 - Low voltage (battery charging required)
 - Low battery voltage detected, power shutdown occurred
 - Solar charging system is charging batteries
 - Batteries are fully charged
- 4.4. Display patterns
 - 4.4.1. All models All arrow boards can display any of the following 7 patterns (for samples, see Exhibit A):
 - Flashing arrow, left or right 10 lights total
5 lights form arrowhead
5 lights form stem
 - Flashing double arrow 13 lights total
5 lights form each arrowhead
3 lights form stem
 - Flashing four-corner warning 4 lights total
1 light at each corner
 - Flashing caution-bar warning 7 lights form horizontal bar across center of display panel
 - Sequencing stem arrow, left or right 10 lights total
5 lights form arrowhead
5 lights form full stem

1st pulse: 2 far stem lights
2nd pulse: 5 far stem lights
3rd pulse: full arrow shape
4th pulse: blank display

4.4.2. 25-light models In addition to the 7 patterns described above, 25-light arrow boards can also display any of the following 5 patterns (for samples, see Exhibit A):

Sequencing walking arrow, left or right	10 lights total 5 lights form arrowhead 5 lights form full stem 1st pulse: 2 far stem lights with arrowhead 2nd pulse: 3 far stem lights with arrowhead 3rd pulse: full arrow shape 4th pulse: blank display
Sequencing chevron arrows, left or right	15 lights total 5 lights form each arrowhead 1st pulse: 1 far arrowhead 2nd pulse: 2 far arrowheads 3rd pulse: 3 arrowheads 4th pulse: blank display
Alternating diamonds	16 lights total 8 lights form each diamond 1st pulse: 1 diamond shape on left 2nd pulse: 1 diamond shape on right

4.5. Electronics

4.5.1. Location	Inside control box
4.5.2. Temperature limits	Operating temperature: -40 to 176°F (-40 to 80°C)
4.5.3. Flash rate	30 to 40 per minute, all display patterns
4.5.4. Positive drive circuit	Positive power applied to lamps only when lit Negative is chassis grounded
4.5.5. Fuse protection	Dual PTC resettable fuses
4.5.6. Reverse-polarity protection	Protects the controller if battery cables are connected backwards (which sometimes happens after servicing)
4.5.7. Low-voltage disconnect	Low-voltage-disconnect circuit engages when battery voltage drops to 11.2Vdc, shutting down power to protect batteries from full discharge
4.5.8. Asset tracker	Factory configured, no user setup needed Automatically sends arrow board data to connected systems via the cloud Connected data includes GPS location, display pattern, on/off state, and compass bearing See “Options and Optional Equipment” for Wanco Fleet Manager option

5. TRAILER

- 5.1. Frame All welded structural steel
- 5.2. Deck Structural deck adds 350 lb. (159kg) to overall weight, creating a low center of gravity and improving stability
- 5.3. Uprights Two uprights supported display panel, reinforced by 23" structural steel gussets, all welded steel construction
- 5.4. Fenders Round, full wheel coverage, bolted to trailer frame, removable and replaceable
- 5.5. Tie-downs One on each front corner of frame, one centered on rear frame
- 5.6. Finish
 - 5.6.1. Prewash Assemblies are run through a five-stage, high-pressure phosphate-wash prior to finish coat
 - 5.6.2. Coating Frame is coated with oven-baked, safety-orange powder-coat finish to ensure durability and corrosion protection
See "Options and Optional Equipment" for color options
 - 5.6.3. Salt spray resistance 1000 hours (ASTM Method B117) with <1/8" (<3.18mm) creep from scribe
 - 5.6.4. QUV exposure 500 hours QUV-B (ASTM Method D4587-05) >75% gloss retention
- 5.7. Axle assembly Tubular, 2000 lb. (907.2kg) capacity, 5 on 4.5" B.C. idler hub
- 5.8. Springs Double-eye leaf springs, 1200 lb. (544.3kg) capacity for each spring
- 5.9. Tires ST205/75D15 steel-belted trailer tires, load rating B
- 5.10. Drawbar
 - 5.10.1. Construction Telescopes inside receiver sleeve welded under trailer frame. Removable for shipping and for added theft protection if needed. Secures with two 1/2-inch diameter bolts.
 - 5.10.2. Material 3" (7.62cm) square steel tubing, 3/16" (0.476cm) wall
 - 5.10.3. Jack Top-wind swivel, 2000-lb. (907kg) capacity, steel footpad, 10" (25cm) total travel
 - 5.10.4. Tow hitch Standard 2-inch ball coupler tow-hitch, SAE Class 2, 3500-lb. (1588kg) capacity. Bolts to drawbar, removable and replaceable.
See "Options and Optional Equipment" for tow-hitch options.
 - 5.10.5. Tow chains Two high-test proof coil chain assemblies, with "latching" S-hooks for towing. Chains attached to drawbar with quick connectors.

Material diameter 0.406" (10.3mm)

	Working load limit	5400 lbs. (2450kg)
	Breaking force	16,200 lbs. (72kN)
5.11.	Stabilizer legs	
5.11.1.	Description	Four stabilizers, mounted on corners of trailer frame, extend downward from front and rear of trailer at 30-degree angle, increasing length of footprint when deployed
5.11.2.	Adjustment	Stabilizers slide up and down in sleeves, adjustable in 1" (2.54cm) increments, held in place by 3/8" (0.95cm) wire lock pin. A lanyard ties each pin to the trailer frame.
5.11.3.	Material	Leg Perforated 1¼" sq. steel tube, 12ga wall, zinc plated Footpad 4" x 6" (10 x 15cm) steel, zinc plated, all edges turned up
5.12.	Wind resistance	Approx. 57mph (91km/h), calculated maximum sustained wind load before overturning, trailer in deployed position supported by four stabilizer legs and one drawbar jack with tires off the ground
5.13.	Wiring	
5.13.1.	Description	Wiring to connect tow vehicle and trailer for trailer taillights is installed inside drawbar, with pigtailed and connectors at both ends; no crimping required
5.13.2.	Trailer plug	A sealed, molded, 4-square connector plugs into harness under trailer
5.13.3.	Tow-vehicle plug	Two-piece assembly with 4-flat molded connector on harness plugs into tow vehicle Meets SAE J1239 See "Options and Optional Equipment" for tow-vehicle plug options
5.13.4.	Protection	All trailer wiring encased in UV protective loom, and attached with P-clamp riveted to trailer frame; no exposed wires
5.14.	Taillights	Two oval-shaped, sealed, LED, combination stop, turn and taillights integrated with fenders
5.15.	Reflectors	Two amber reflectors, one on the side of each upright Two red reflectors on rear trailer frame See "Options and Optional Equipment" for reflective tape
5.16.	License plate	Lighted license plate holder is mounted under rear of trailer frame
5.17.	Winch assembly	
5.17.1.	Function	Hand-operated winch raises and lowers display panel
5.17.2.	Capacity	1500 lbs. (680kg)
5.17.3.	Brake	Safety friction-brake prevents display panel from falling if operator loses grip on winch handle

- 5.17.4. Cable 1/4" (6.35mm) diameter galvanized aircraft cable
- 5.18. Slide-bar assembly
 - 5.18.1. Function Locks display panel in place, ensuring panel cannot fall even if winch or cable were to fail. Slides up and down inside sleeve when winch is operated.
Located off-center on upper crossbar between uprights. Sleeve is mounted to crossbar. Slide-bar is mounted to back of display panel.
 - 5.18.2. Locking pin One 3/8" (0.95cm) wire lock pin holds slide bar and display panel in deployed or travel position. A lanyard ties the pin to the trailer frame.
 - 5.18.3. Material Perforated 1¾" sq. steel tube, 12ga wall, zinc plated
 - 5.18.4. Sight tube A sight tube for aiming the arrow board in desired direction is mounted to the left upright

6. POWER SYSTEM

- 6.1. Description Electronics powered by batteries, which are charged automatically with integrated solar charging system
- 6.2. Batteries
 - 6.2.1. Type Leak- and spill-proof valve-regulated lead acid (VRLA)
See "Options and Optional Equipment" for battery options
 - 6.2.2. Features 100% maintenance-free
Sealed and spill-proof
Faster recharge and greater freeze resistance than conventional batteries
Smaller and lighter-weight than conventional batteries
Contains 80% less lead when compared to conventional batteries
 - 6.2.3. Quantity Two
 - 6.2.4. Voltage 12Vdc each
 - 6.2.5. Weight 12.5 lbs. (6kg) each
 - 6.2.6. Capacity 36 Ah total @ 12Vdc
 - 6.2.7. Location Inside structural deck
- 6.3. Solar
 - 6.3.1. Panels One high-efficiency multi-crystal photovoltaic solar module
 - 6.3.2. Location Above display panel, no shadowing effect on any trailer component. Articulated supports ensure solar array remains flat for continuous charging regardless of display panel position.

- 6.3.3. Power 50W
See “Options and Optional Equipment” for solar options
- 6.3.4. Current 2.89A max. system current
3.22A open short-circuit current
- 6.3.5. Voltage 17.3Vdc max.
21.6Vdc open short-circuit voltage
- 6.3.6. Regulation Solar panels regulated by arrow board controller
- 6.3.7. Security Solar panel bolted to mounting frame with security screws and special security nut

7. DIMENSIONS & WEIGHT

7.1. Dimensions *inches (cm)*

Travel position

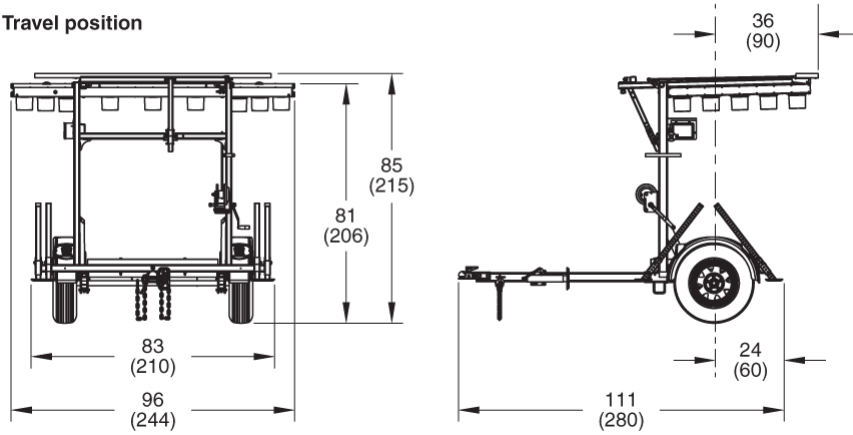

Deployed

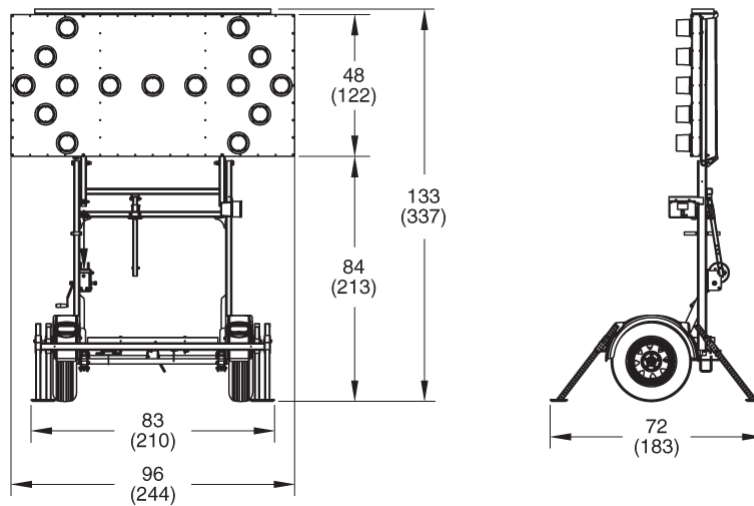





7.2. Weight Approx. 1250 lbs. (567kg)





8.9. Wanco Fleet Manager	Description	Web-based service provides online access to connected arrow boards remotely and wirelessly
	Features	Remote access with easy-to-use dashboard View GPS location and compass bearing on detailed map View arrow board display pattern, display on/off state, voltages and alarms View trailer stance, including tip-over status Set up and receive system alerts via text or email Execute remote command to set 4-corner-caution pattern or blank the display (available only in some operating modes) View system performance Review operation history log and audit trail
	System requirements	Modern standards-compliant Web browser with JavaScript enabled A platform that supports one of these browsers (smartphone, tablet, or computer) Internet connection

EXHIBIT A: DISPLAY PATTERNS

Flashing patterns

Pulse 1	Pulse 2	
		Flashing arrow, left or right
		Flashing double arrow
		Flashing four-corner warning
		Flashing caution-bar warning

Sequential patterns

Pulse 1	Pulse 2	Pulse 3	Pulse 4	
				Sequencing arrow, left or right
				Sequencing stem arrow, left or right*
				Sequencing chevron arrows, left or right*
				Alternating diamonds*

**Available only on 25-light arrow board models*