

AUTOMATED FLAGGER ASSISTANCE DEVICE

MODEL WAFD
PRODUCT SPECIFICATIONS | MAY 2026

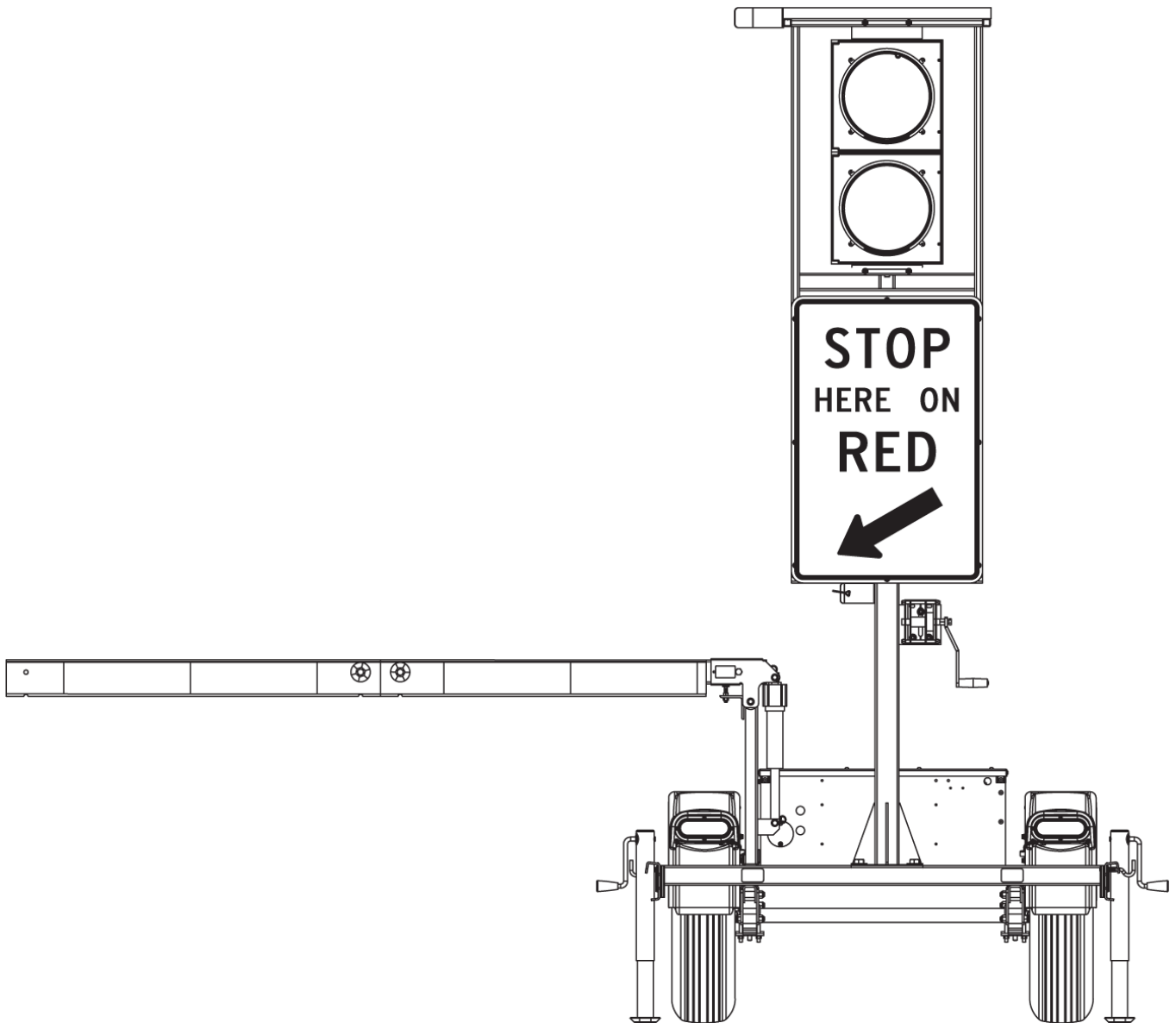

1. SYSTEM

1.1. Description

The Wanco® Automated Flagger Assistance Device (AFAD) is a portable flagging station that enables a human flagger to remain off the road, out of the path of moving traffic, while the AFAD provides motorists with clear guidance through a temporary traffic control (TTC) zone.

Principal components of the Wanco® AFAD are its mechanical gate arm, dual red and yellow signal lights, regulatory “STOP HERE ON RED” sign, and wireless controller. The gate arm blocks traffic when it is down, and allows traffic to pass when it is up. The signal lights change automatically in coordination with the gate arm position: a red light tells motorists to stop while the arm is down, and a yellow light flashes continually while the arm is up.

The AFAD operator is in full control of the gate arm, manually triggering changes in gate arm position, and can operate either one or two AFADs with one controller. The controller offers configuration options to suit the work zone and the operator’s needs.

The Wanco AFAD is compact and portable, making it easy to tow and deploy. Two AFAD trailers can be towed together by a single vehicle.

Power is provided by batteries, which are charged by an automated solar charging system. The remote control is continually charged by the AFAD power system when stored inside the lockable battery box.

1.2. Model

WAFD Automated Flagger Assistance Device

1.3. Temperature limits

Operating –4 to 158°F (–20 to 70°C)

Storage –22 to 176°F (–30 to 80°C)

1.4. Standards

Compliant in accordance with:

MUTCD, December 2023

FCC part 15 class A

2. FEATURES

2.1. Setup

- Compact system is easy to transport and deploy
- Tow one trailer or two trailers
- Leveling jacks raise trailer tires off the ground to provide stability
- Heavy-duty hand-winch allows one person to easily raise and lower the sign and lights
- Single auto-locking device holds the tower in place while operating and during transport
- Gate arm remains attached during transport and for storage
- Gate arm extension can be removed and stowed
- Easy pairing with wireless controller

- 2.2. Operation**
 - Remote control allows human flagger to remain off the road
 - Wireless controller and cable-connected controller both included
 - Flexible operation for one or two operators and AFADs
 - Large signal lights are highly visible
 - Operator can enable haul-road crossing mode
 - Intrusion alarm activated from wireless controller

- 2.3. Wireless controller**
 - Full-color touchscreen with high-resolution display
 - Intuitive easy-to-use interface
 - Large AFAD buttons continuously indicate gate position and signal light behavior
 - Prohibited operations are “grayed out” and inactive
 - When two AFADs are controlled by one operator, the main control screen prevents both AFAD gates from opening at the same time
 - Continuous display of wireless signal strength and power indicators
 - Large “All Stop” button closes any open gate
 - Individual vehicle-intrusion alarm buttons for each paired AFAD

- 2.4. Cabled controller**
 - Single large button opens and closes gate
 - When cable is connected to control box, prevents wireless control

- 2.5. Power system**
 - Battery powered and solar charging
 - Energy-efficient operation results in long run times
 - Solar panel charges batteries automatically without intervention
 - Charging system shuts down when batteries are fully charged, preventing damage
 - Power system allows battery charging with solar panel or shore power
 - Cooling fan protects battery charger from overheating
 - Battery box includes cradle and charger for wireless controller
 - Battery box can be locked to prevent unauthorized access

- 2.6. Maintenance**
 - Standard trailer tires
 - Bolt-on fenders can be replaced if damaged
 - Durable powder-coat finish resists the elements

- 2.7. Application**

Common applications include:

 - Temporary traffic control zones
 - Pavement patching operations
 - Bridge maintenance
 - Roadwork zones
 - Partial road closures
 - Haul road crossings

3. GATE

3.1. Gate arm

- 3.1.1. Description Two-section tilting gate arm blocks passage of traffic in a single adjacent travel lane when tilted down in horizontal position
- 3.1.2. Tilt Gate arm attached to tilt bracket that moves the arm up and down between horizontal (blocking traffic lane) and vertical (allowing traffic flow)
- Tilt bracket movement controlled by electric actuator attached to tilt bracket at the top and the trailer frame at the bottom
- 3.1.3. Construction Primary arm section attached to tilt bracket with one bolt
- Second arm section doubles gate length by attaching to the free end of the primary section with a rigid connector
- Connector uses tool-less hardware for easy installation and removal
- 3.1.4. Size Rectangular tubing
- 3.079" x 2.128" (78.23 x 54.05 mm), H x D
- 8 ft (2.44 m) total length, two sections of 4 ft (1.22 m) each
- See "Options and Optional Equipment" for alternate sizes
- 3.1.5. Material Polyvinyl chloride (PVC), non-metallic
- 3.2. Conspicuity Highly reflective microprismatic conspicuity tape on both vertical sides of gate arm, with alternating vertical red and white stripes at 16-inch (40.6 cm) intervals (3M™ GA1616); tape runs along entire length of gate arm
- 3" (7.62 cm) height
- See "Options and Optional Equipment" for alternate conspicuity tape
- 3.3. Actuator 12 Vdc electric actuator
- 6" stroke at 250 lb max. load (15.24 cm stroke at 113.4 kg max. load)

4. REGULATORY SIGN

- 4.1. Description Standard R10-6 "STOP HERE ON RED" sign
- 4.2. Location Mounted to tower that rises up for improved visibility when deployed and lowers for transport and storage
- 4.3. Size 24" x 36" (61 x 91 cm), W x H
- 4.4. Material Aluminum sheet, 0.080" (2 mm) thick
- White reflective coating (3M 4090-series high-intensity prismatic sheet, ASTM D4956 Type XI)

5. SIGNAL LIGHTS

5.1. Dual signal beacons

- 5.1.1. Description Two LED beacon assemblies attached one above the other with colored lights
- 5.1.2. Housing 12-inch yellow polycarbonate beacon head (Mobotrex® SA101A1C11YY00)
Hinged door provides access to interior, light, and wiring
Tunnel type visor extends 9.75" (24.8 mm) from door surface
- 5.1.3. Beacon colors Red light on top beacon (Leotek® T12R-LX6-1A281)
Yellow light on bottom beacon (Leotek T12Y-LX6-1A281)
- 5.1.4. Location Mounted to tower that rises up for improved visibility when deployed and lowers for transport and storage

5.2. Behavior

Gate open	Flashing yellow signal
Gate open, 5-second countdown before closing	Steady yellow signal
Gate closing	Steady red signal
Gate closed	Steady red signal
Gate opening	Steady red signal

5.3. Flash rate

50 times per minute
50% duty cycle

6. SIREN

6.1. Description

Alerts road workers when traffic has improperly entered the traffic control zone; siren sounds when the operator activates the intrusion alarm using the wireless controller

6.2. Sound

1-tone siren, 110 dB

6.3. Power

15 W, 12 Vdc

6.4. Rating

Rated for outdoor use

7. CONTROL SYSTEM

7.1. Description

Self-contained onboard control system manages signal light and gate arm functions

7.2. Control box

- 7.2.1. Function Weatherproof control box contains system electronics
- 7.2.2. Size 11" x 14.9" x 5.11" (28 x 38 x 13 cm), W x H x D
- 7.2.3. Material Acrylonitrile butadiene styrene (ABS), gray
- 7.2.4. Location Securely fastened to tower

7.2.5.	Door	Front-panel is a door, hinged on the left, which opens fully Two stainless steel latches hold door closed Door can be locked with user-supplied padlock for added security
7.2.6.	Pair button	Initiates pair mode to support linking wireless controller with onboard control system Momentary switch behind a rubber boot on bottom of control box
7.3.	Wiring	All control system wiring routed inside liquid-tight loom, and attached with P-clamps riveted to trailer frame; no exposed wiring. Wiring service loop is designed to allow tower with signal lights to be raised and lowered.
7.4.	Wireless controller	
7.4.1.	Description	Wireless touchscreen controller provides access to all control functions for one or two paired AFADs
7.4.2.	Touchscreen	
	Display	Full color, backlit, 4.3-inch display Resistive touch panel 480 x 272 pixels, W x H Display remains on continuously while in use, and automatically shuts off after 15 minutes of inactivity
	Interface	Main screen provides gate arm control for paired AFADs, intrusion alarm control, battery charge and signal strength indicators, power indicators for auxiliary equipment if installed, and access to settings and system information screens Settings screen provides access to pairing and other functions System information screen provides: <ul style="list-style-type: none">• Software and hardware versions• Battery voltages for controller and paired AFADs• Wireless signal strength for controller and paired AFADs• Alert indicators for voltages and signal strength• FCC regulatory declaration See Exhibit A for sample screens and additional information
7.4.3.	Housing	Molded impact-resistant EPDM rubber, dark gray Flexible material tightly wraps around and holds together the controller and battery pack Ported for insertion of charger connector Includes integral sunshade and holes for connecting neck strap
7.4.4.	Neck strap	Adjustable neck strap can be detached and replaced when needed Two double-hook “S” shape carabiners connect strap to controller housing

- 7.4.5. Storage Cradle located inside battery box, holds controller assembly for storage, charging, and transport
- 7.4.6. Power 8-cell, Li-ion battery pack, lasts 60 hours on a single charge
Typical charging time is approximately 12 hours from fully depleted to fully charged
7.2 V, 14 Ah capacity
- 7.4.7. Charging 12 Vdc to 8.4 Vdc system charger with power cord
Power cord plugs into charging port on bottom of controller
Located inside battery box
- 7.4.8. Radio transceivers XBee-PRO® 900HP Point2Multipoint, 902-928 MHz, 10 Kbps
1000 ft (305 m) range from controller to AFAD trailer
- 7.4.9. Antennas
 - Controller 1/4-wave wire whip integrated antenna
 - AFAD Yagi RF antenna, 4-element, 896–980 MHz, 8 dBd

7.5. Cabled controller

- 7.5.1. Description Cable-connected push-button controller provides control of gate arm on connected AFAD
While connected, prevents wireless connection
- 7.5.2. Function Single push-button controls gate arm up/down motion
- 7.5.3. Cable Hard-wired to controller; loose end fitted with connector and retaining ring for attaching to port on bottom of control box
Length: 15 ft (4.6 m)

8. TRAILER

- 8.1. Frame All welded structural steel
- 8.2. Tie-downs Two tie-downs: one centered on front of frame, one centered on rear of frame
- 8.3. Finish Oven-baked, safety-orange powder-coat finish to ensure durability and corrosion protection. Assemblies are bead-blasted and then run through a five-stage, high-pressure phosphate-wash prior to application of the finish coat.
See “Options and Optional Equipment” for color options.
- 8.4. Fenders Round, full wheel coverage, bolted to trailer frame, removable and replaceable
- 8.5. Axle assembly 1200 lb (544 kg) capacity, 5 on 4.5" B.C. idler hub
- 8.6. Springs Double-eye leaf springs

- 8.7. Tires** ST205/75R15 radial trailer tires, load rating C, speed rating M
- 8.8. Drawbar**
 - 8.8.1. Construction Telescopes inside receiver sleeve welded under trailer frame. Removable for shipping and for added theft protection if needed. Secured with two 1/2-inch (12 mm) diameter bolts.
 - 8.8.2. Material Square tubing, 3" x 3/16" wall (7.62 x 0.476 cm wall)
 - 8.8.3. Jack Swivel jack with steel footpad
 - 8.8.4. Tow hitch Standard 2-inch ball coupler tow-hitch, SAE Class 2, 3500 lb (1588 kg) capacity. Bolts to drawbar, removable and replaceable.
See "Options and Optional Equipment" for tow-hitch options.
 - 8.8.5. Tow chains Two high-test proof coil chain assemblies with clevis slip hooks for towing
Chains are attached with quick connectors to welded loops on drawbar
- 8.9. Tandem tow hitch** Rear-mounted 2-inch ball hitch for tandem towing two AFAD trailers with one tow vehicle
See "Options and Optional Equipment" for tandem- and dual-tow options
- 8.10. Stabilizer jacks** Four swivel jacks, each with 2000 lb (907 kg) capacity, mounted on corners of trailer frame
- 8.11. Wiring**
 - 8.11.1. Description Wiring to connect tow vehicle and trailer for trailer taillights is installed inside drawbar, with pigtails and connectors at both ends; no crimping required
 - 8.11.2. Trailer plug A sealed, molded, 4-square connector plugs into harness under trailer
 - 8.11.3. Tow-vehicle plug Two-piece assembly with 4-flat molded connector on harness plugs into tow vehicle
Meets SAE J1239
See "Options and Optional Equipment" for tow-vehicle plug options
 - 8.11.4. Protection All trailer wiring encased in UV protective loom, and attached with P-clamp riveted to trailer frame; no exposed wires
- 8.12. Taillights** Two oval-shaped, sealed, LED, combination stop, turn and taillights integrated with fenders
- 8.13. Reflectors** Sides of trailer have amber reflectors near front
See "Options and Optional Equipment" for reflective tape
- 8.14. License plate** Lighted license plate light holder is mounted under rear of trailer frame
- 8.15. Tower assembly**
 - 8.15.1. Function Signal lights and regulatory sign are raised and lowered on a tower

- 8.15.2. Construction Two sections of square steel tubing with the inner section telescoping inside the outer section.
Nylon guide blocks keep the sections tight, eliminating the need for greasing the tower and preventing dirt from building up on the inner tower section. Dirt would cause performance problems and maintenance issues.
- 8.15.3. Finish Lower tower section and base are coated with oven-baked, safety-orange powder-coat finish to ensure durability and corrosion protection. Assemblies are run through a five-stage, high-pressure phosphate-wash prior to application of the finish coat.
Upper tower section is treated for corrosion resistance.
See “Options and Optional Equipment” for color options.
- 8.15.4. Winch assembly
- | | |
|----------|--|
| Function | Hand-operated winch raises and lowers the tower |
| Capacity | 1000 lb (453.6 kg) |
| Brake | Safety friction-brake prevents tower from falling if operator loses grip on winch handle |
| Cable | 3/16" (4.76 mm) diameter galvanized aircraft cable |
- 8.15.5. Height lock Spring-loaded locking pin prevents tower from falling if the winch or cable were to fail

9. POWER SYSTEM

- 9.1. Description Electronics powered by batteries, which are charged automatically with integrated solar charging system
- 9.2. Battery box
- 9.2.1. Function Holds batteries and remote charger
See “Options and Optional Equipment” for heavy-duty secure battery box
- 9.2.2. Construction Riveted all-steel construction
All parts powder-coated before assembly
Divider panel inside box separates batteries from electronics
Louvers provide ventilation
Latches keep cover closed and can accept user-supplied padlocks
- 9.2.3. Location Centered between fenders, bolted to trailer frame
- 9.3. Batteries
- 9.3.1. Description Four deep-cycle golf-cart-type batteries, wired in parallel and series for a 12-volt system
See “Options and Optional Equipment” for battery options

- 9.3.2. Voltage 6 Vdc each
- 9.3.3. Weight Approx. 60 lb (26 kg) each
- 9.3.4. Capacity 440 Ah total capacity @ 12 Vdc
- 9.3.5. Low-voltage disconnect (LVD) To protect batteries from full discharge, the LVD system automatically shuts down power when battery voltage drops to preset level, and re-engages power when battery charge returns to optimum

9.4. Remote charger

- 9.4.1. Function Plugs into a standard AC shore power source to recharge batteries if battery voltage drops due to lack of sun for automated solar charging system
- 9.4.2. Type 12-volt battery charger
- 9.4.3. Location Inside battery box, mounted to divider panel on opposite side from batteries
- 9.4.4. Output capacity 15 A
- 9.4.5. Output voltage 13.2 Vdc range float mode
13.6 Vdc range absorption mode
14.2 Vdc range bulk mode
- 9.4.6. Input voltage 105 to 135 Vac, standard three-prong plug
- 9.4.7. Input frequency 50 to 60 Hz
- 9.4.8. Cooling Automatic fan cooling

9.5. Solar

- 9.5.1. Panels One high-efficiency photovoltaic solar module
- 9.5.2. Location Top of tower. Solar panel array lies flat and rises with tower. No shadowing effect from any trailer component.
- 9.5.3. Power 100 W
See "Options and Optional Equipment" for solar options
- 9.5.4. Current 4.81 A operating current (Imp)
5.08 A short-circuit current (Isc)
- 9.5.5. Voltage 20.84 Vdc operating current (Vmp)
24.07 Vdc open circuit voltage (Voc)
- 9.5.6. Regulation Solar power input regulated by control system

10. DIMENSIONS & WEIGHT

10.1. Dimensions

10.1.1. AFAD

*inches
(cm)*

Travel position



Deployed

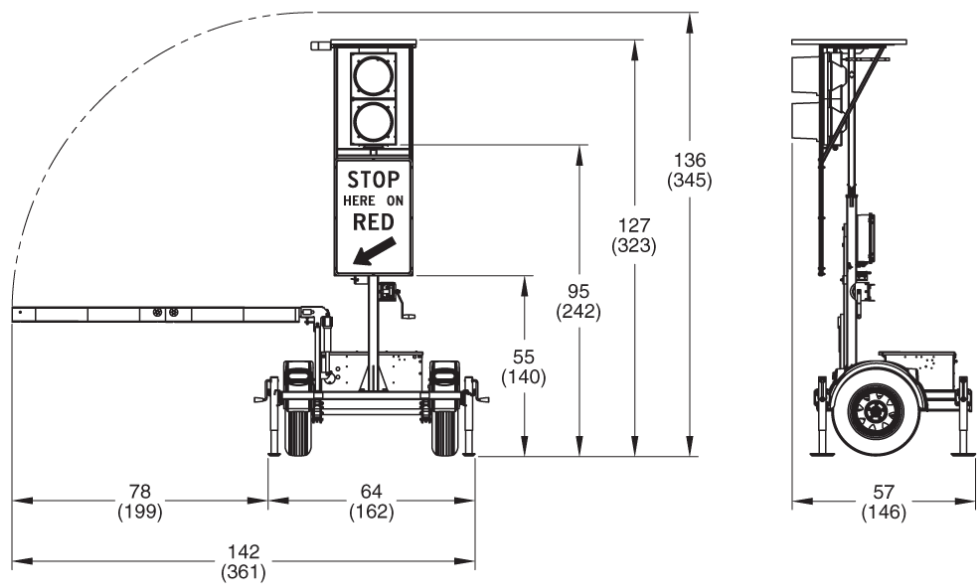

10.1.2. Wireless controller *inches
(cm)*

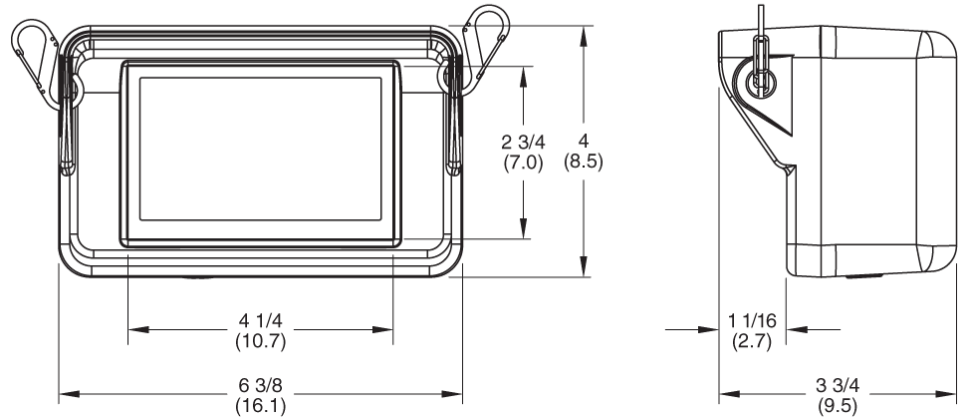

10.2. Weight

10.2.1. AFAD Approx. 875 lb (397 kg)

10.2.2. Wireless controller Approx. 2 lb (1 kg)

11. OPTIONS AND OPTIONAL EQUIPMENT

11.1. Lights

- 11.1.1. Signals backplate Black backplate provides a dark silhouette around signal lights, shielding them from background light and obstructions
- 11.1.2. Indicator light Rear-facing light installed behind signal lights, for when the operator's location prevents direct viewing of the signal lights

11.2. Gate arm

- 11.2.1. Arm Replace standard gate arm with alternate arm
- Options 3-inch (7.62 cm) arm height with right-slant diagonal stripes
 4 1/2-inch (11.43 cm) arm height with vertical stripes
- 11.2.2. Short extension Additional extension lengthens arm by 2 feet (61 cm)
- 11.2.3. Flag Flag attaches to end of gate arm and hangs from arm; easily removable
 24" (61 cm) square, fluorescent orange vinyl
- 11.2.4. Breakaway arm Allows gate to swing out of the way when struck by a passing vehicle, reducing chance of damage. Spring-tensioned mechanism returns arm to default position.

11.3. Towing

- 11.3.1. Drawbar tow hitch
- Description Selected option replaces standard tow hitch
- Options Combo-hitch for 2-inch ball and 2 1/2-inch ID x 1-inch cross-section pintle hook
 Standard-duty lunette ring for 2 1/2-inch ID x 1-inch cross-section pintle hook
 Heavy-duty lunette ring for 3-inch ID x 1 5/8-inch cross-section pintle hook
- 11.3.2. Tandem tow hitch Pintle hook for 2 1/2-inch to 3-inch lunette ring, replaces standard tandem-tow hitch; not compatible with nested dual-tow coupler
- 11.3.3. Nested dual-tow coupler Dual-tow coupler allows towing two AFAD trailers nested together as though they were a single unit; not compatible with tandem tow hitch
- 11.3.4. Tow-vehicle plug Many types of plugs available, prewired at the factory; contact factory for details

11.4. Power

- 11.4.1. Additional batteries
- Function For geographic locations with less solar charging potential or colder weather, and for applications that require year-round charging, add batteries for greater capacity
- Option Two additional 6 Vdc deep-cycle batteries, 220 Ah additional capacity

11.4.2. AGM batteries

Function	Replace deep-cycle batteries with top-of-the-line absorbed glass mat (AGM) batteries
Features	100% maintenance-free Leak-proof and spill-proof Faster recharge and greater freeze resistance than conventional batteries Contains less lead than conventional batteries
Weight	Approx. 160 lb (72kg) each
Options	Two 4D AGM 12 Vdc batteries, 400 Ah total capacity Three 4D AGM 12 Vdc batteries, 600 Ah total capacity

11.4.3. Remote charger

Function	When required for added battery charging capacity, replace standard remote charger with higher amperage charger
Option	12-volt, 45-amp charger
Output voltage	13.4 Vdc @ full load 13.6 Vdc standard float voltage 14.2 Vdc with dual-voltage jack installed
Input voltage	108 to 132 Vac, standard three-prong plug
Input frequency	50 to 60 Hz

11.4.4. Solar

Function	For geographic locations with less solar charging potential or colder weather, and for applications that require year-round charging, additional solar power is available
Option	130W solar panel replaces standard solar panel
Current	6.25 A operating current (Imp) 6.60 A short-circuit current (Isc)
Voltage	20.98 Vdc operating voltage (Vmp) 24.70 Vdc open circuit voltage (Voc)

11.5. Trailer

- | | |
|----------------------------|---|
| 11.5.1. Secure battery box | High-security battery box features heavy-gauge steel lid, hidden hinges, and heavy-duty hidden-shackle padlocks. Replaces standard battery box. |
| 11.5.2. Reflective tape | Reflective red-and-white conspicuity tape across rear trailer frame for increased visibility |
| 11.5.3. Finish color | Specify power-coat color and, if applicable, color scheme |

11.6. Camera

11.6.1. Function	Day/night IR dome camera Field of view is vehicles in the approach lane of traffic and the AFAD gate arm; the camera view can be adjusted manually Used for making video recording; not intended for AFAD operation, live view, or remote control
11.6.2. Resolution	2 MP 1080p
11.6.3. Video	Time-and-date-marked video is recorded continuously while power is applied, video files are stored on local memory card
11.6.4. Storage	Micro SD memory slot, 128 GB max. When memory card is full, the oldest video file is overwritten by the newest file Typical 7-day capacity before overwrite; actual capacity dependent on camera settings
11.6.5. Temperature limits	
Operating	-22 to ~130°F (-30 to ~55°C)
Startup	Min. -4°F (-20°C)
Storage	-22 to ~140°F (-30 to ~60°C)
11.6.6. Humidity limit	Less than 90% RH
11.6.7. Rating	IP66

EXHIBIT A: WIRELESS CONTROLLER SCREENS

